

NAN YA PLASTICS CORP.
ELEC. MATERIALS DIV.
LCD DEPARTMENT

SPECIFICATION

SPEC. NO. : LM075-0
DATE : Sep. 17, 1997
SHEET NO. : 1/20

U.S. MARKETING ARM:

MARK PRODUCTS CORPORATION
800 N. EDGEWOOD AVENUE
WOOD DALE, IL 60191
TEL: 630-787-9089
FAX: 630-787-9015

SPECIFICATION OF
40x2 LCD MODULE
PRODUCT NO.: LM_J3_075_E_

SPEC. NO.: LM075-0

APPROVED BY

EDITED ON : Sep. 17, 1997

TECHNICAL MANAGER	DESIGN MANAGER	PERSON IN CHARGE

REV/DATE	RO/ 09.17.97'					APP	CHK	BY
----------	------------------	--	--	--	--	-----	-----	----

1. MECHANICAL DATA

- (1) Product No. LM_J3_075_E_
- (2) Module Size
182.0 (W)mm x 33.5 (H)mm x MAX14.5 (D)mm (ARRAY TYPE LED B.L.)
182.0 (W)mm x 33.5 (H)mm x MAX12.5 (D)mm (EDGE TYPE LED B.L.)
182.0 (W)mm x 33.5 (H)mm x MAX9.5 (D)mm (W/O,EL B.L.)
- (3) Dot Size 0.6 (W)mm x 0.65 (H)mm
- (4) Dot Pitch 0.65 (W)mm x 0.70 (H)mm
- (5) Number of Characters 40 (W) x 2 (H)Characters
- (6) Character Format 5 (W) x 8 (H)Dots
- (7) Duty 1/16
- (8) LCD Display Mode
STN: Gray Mode Yellow Mode Blue Mode
FSTN: Black and White(Normal White/Positive Image)
 Black and White(Normal Black/Negative Image)
- Rear Polarizer: Reflective Transflective Transmissive
- (9) Viewing Direction 6 O'clock 12 O'clock ___ O'clock
- (10) Backlight W/O LED EL
- (11) Weight
W/O B/L: 63.3 g
EL B/L: 67.0 g
ARRAY TYPE LED B/L: 88.4 g
EDGE TYPE LED B/L: 81.5 g

Note :

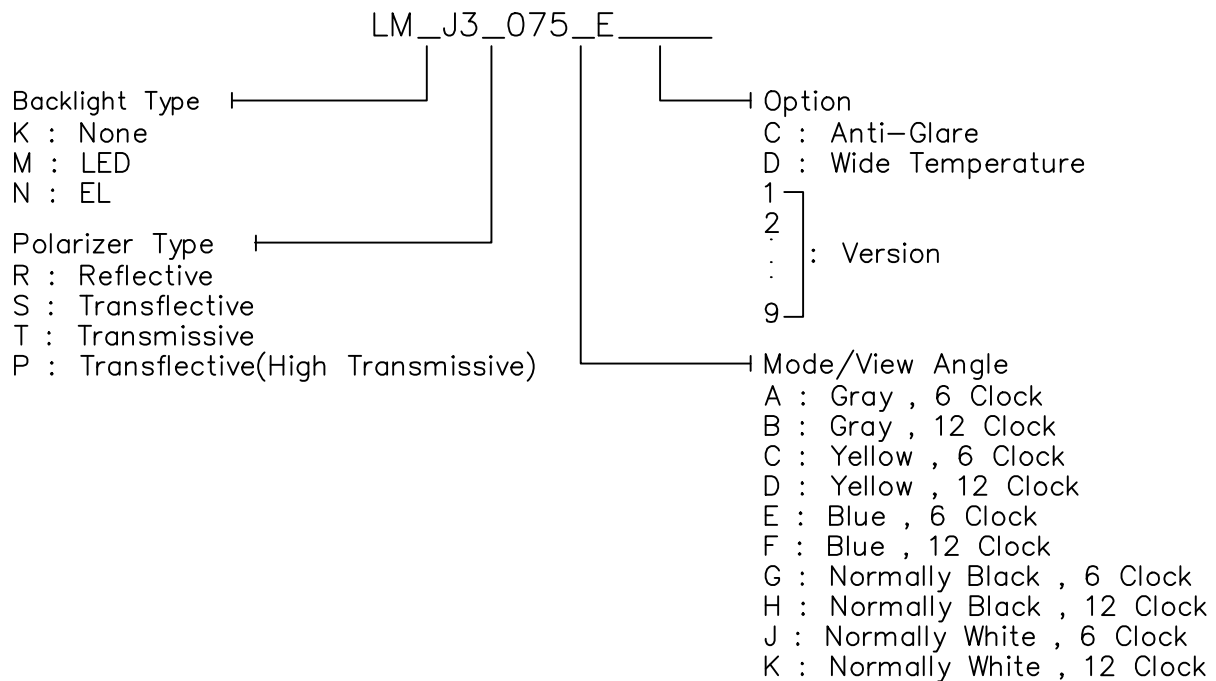

REV/DATE	R0/ 09.17.97'					APP	CHK	BY
----------	------------------	--	--	--	--	-----	-----	----

2. ABSOLUTE MAXIMUM RATINGS

(1) ELECTRICAL ABSOLUTE RATINGS

V_{SS}=0V

	SYMBOL	MIN	MAX	UNIT	COMMENT
Power Supply for Logic	VDD-VSS	-0.3	6.5	V	
Input Voltage	V _I	-0.3	VDD	V	
Static Electricity	-	-	-	-	Note 1

Note 1 LCM should be grounded during handling LCM.

(2) ENVIRONMENTAL ABSOLUTE MAXIMUM RATINGS

ITEM	NORMAL TEMP.				WIDE TEMP.			
	OPERATING		STORAGE		OPERATING		STORAGE	
	MIN.	MAX.	MIN.	MAX.	MIN.	MAX.	MIN.	MAX.
Ambient Temperature	0	50	-20	70	-20	70	-30	80
Humidity (Without Condensation)	Note 1,3		Note 2,3		Note 3,4		Note 3,5	

Note 1 Ta ≤ 50°C : 85%RH max

Ta > 50°C : Absolute humidity must be lower
than the humidity of 85%RH at 50°C

Note 2 Ta at -20°C will be < 48hrs, at 70°C will be < 120hrs

Note 3 Background color changes slightly depending on ambient temperature.
This phenomenon is reversible.

Note 4 Ta ≤ 70°C : 75%RH max

Ta > 70°C : Absolute humidity must be lower
than the humidity of 75%RH at 70°C

Note 5 Ta at -30°C will be < 48hrs, at 80°C will be < 120hrs

REV/DATE	R0/ 09.17.97'					APP	CHK	BY
----------	------------------	--	--	--	--	-----	-----	----

3. ELECTRICAL CHARACTERISTICS

(FRAME FREQUENCY : 70 Hz)

(VDD=5V±10%)

ITEM	SYMBOL	CONDITION	MIN.	TYP.	MAX.	UNIT
Input Voltage	V _{IH}	H level	0.8V _{DD}	—	V _{DD}	V
	V _{IO}	L level	0	—	0.2V _{DD}	V
Recommended LCD Driving Voltage (NORMAL TEMP. LCM)	V _{DD} -V _O (V _{op})	0℃	—	4.8	5.4	V
		25℃	4.2	4.7	5.2	
		50℃	3.8	4.3	—	
Recommended LCD Driving Voltage (WIDE TEMP. and DOUBLE POWER LCM)	V _{DD} -V _O (V _{op})	-20℃	—	6.4	7.2	V
		0℃	—	6.4	—	
		25℃	—	6.2	—	
		50℃	—	5.9	—	
		70℃	5.2	5.5	—	
Recommended LCD Driving Voltage (WIDE TEMP. and SINGLE POWER LCM)	V _{DD} -V _O (V _{op})	-20℃	4.5	4.9	5.4	V
		0℃	4.2	4.7	5.1	
		25℃	4.1	4.6	5.0	
		50℃	—	—	—	
		70℃	3.6	4.0	4.5	
Power Supply Current	I _{DD}	V _{DD} = 5.0V	—	—	2.8	mA
LED Power Supply Current	I _{LED}	V _{BL} = 5V _{Dc} (R _{BL} = 5Ω)	—	200	—	mA
EL Power Supply Current	I _{EL}	V _{BL} = 110V _{Ac} 400Hz	—	—	5.0	mA
EDGE TYPE LED Power Supply Current	I _{LED}	V _{BL} = 5V _{Dc} (R _{BL} = 5Ω)	—	170	—	mA

4-1. OPTICAL CHARACTERISTICS

(FOR NORMAL TEMPERATURE MODE LCM)

AT Vop

ITEM MODE		Cr(Contrast Ratio)		θ (Viewing Angle)		ϕ (Viewing Angle)	
		25℃		25℃		25℃	
		MIN.	TYP.	MIN.	TYP.	MIN.	TYP.
R	A	3.0	4.0	40	65	25	35
	C	5.0	8.0	50	70	28	38
	J						
S	A	3.0	4.0	35	60	20	32
	C	4.0	7.0	45	65	25	35
	J						
T	E/F	2.5	3.0	30	50	20	30
	C/D	2.5	5.0	30	50	20	30
NOTE		NOTE6		NOTE5			

AT $\phi=0^\circ$ $\theta=0^\circ$

ITEM	SYMBOL	CONDITION	MIN.	TYP.	MAX.	UNIT	NOTE
Response Time (rise)	Tr	0℃	-	460	900	ms	NOTE 2
		25℃	-	110	220		
		50℃	-	65	130		
Response Time (fall)	Tf	0℃	-	420	800	ms	NOTE 2
		25℃	-	140	250		
		50℃	-	90	155		

NOTE :

R: REFLECTIVE
S: TRANSFLECTIVE
T: TRANSMISSIVE
A/B: GRAY
C/D: YELLOW
E/F: BLUE
G/H: NORMALLY BLACK
J/K: NORMALLY WHITE

4-2.OPTICAL CHARACTERISTICS

(FOR WIDE TEMPERATURE and DOUBLE POWER MODE LCM)

AT Vop

ITEM MODE		Cr(Contrast Ratio)		θ (Viewing Angle)		ϕ (Viewing Angle)	
		25℃		25℃		25℃	
		MIN.	TYP.	MIN.	TYP.	MIN.	TYP.
R	A	3.0	4.5	50	70	25	30
	C	4.5	10	50	75	30	40
	J						
S	A	3.0	4.0	40	60	25	34
	B	3.0	4.0	40	60	25	34
	C	4.5	10	50	75	30	40
T	E						
	G						
NOTE		NOTE6		NOTE5			

AT $\phi=0^\circ$ $\theta=0^\circ$

ITEM	SYMBOL	CONDITION	MIN.	TYP.	MAX.	UNIT	NOTE
Response Time (rise)	Tr	-20℃	-	1500	3000	ms	NOTE 2
		0℃	-	270	540		
		25℃	-	130	260		
		50℃	-	70	140		
		70℃	-	65	130		
Response Time (fall)	Tf	-20℃	-	2000	4000	ms	NOTE 2
		0℃	-	310	600		
		25℃	-	90	180		
		50℃	-	48	100		
		70℃	-	40	80		

NOTE :

R: REFLECTIVE
S: TRANSFLECTIVE
T: TRANSMISSIVE
A/B: GRAY

C/D: YELLOW
E/F: BLUE
G/H: NORMALLY BLACK
J/K: NORMALLY WHITE

REV/DATE	R0/ 09.17.97'					APP	CHK	BY
----------	------------------	--	--	--	--	-----	-----	----

4-3. OPTICAL CHARACTERISTICS

(FOR WIDE TEMPERATURE and SINGLE POWER MODE LCM)

AT Vop

ITEM MODE		Cr(Contrast Ratio)		θ (Viewing Angle)		ϕ (Viewing Angle)	
		25℃		25℃		25℃	
		MIN.	TYP.	MIN.	TYP.	MIN.	TYP.
R	A/B	3.5	4.5	40	60	25	40
	C						
	J						
S	A						
	C	5.0	8.0	45	70	25	40
	C						
T	E						
	G						
NOTE		NOTE6		NOTE5			

AT $\phi=0^\circ$ $\theta=0^\circ$

ITEM	SYMBOL	CONDITION	MIN.	TYP.	MAX.	UNIT	NOTE
Response Time (rise)	Tr	-20℃	-	1900	3800	ms	NOTE 2
		0℃	-	265	530		
		25℃	-	90	180		
		50℃	-	-	-		
		70℃	-	60	120		
Response Time (fall)	Tf	-20℃	-	2700	4500	ms	NOTE 2
		0℃	-	450	715		
		25℃	-	170	260		
		50℃	-	-	-		
		70℃	-	50	110		

NOTE :

R: REFLECTIVE
 S: TRANFLECTIVE
 T: TRANSMISSIVE
 A/B: GRAY

C/D: YELLOW
 E/F: BLUE
 G/H: NORMALLY BLACK
 J/K: NORMALLY WHITE

REV/DATE	R0/ 09.17.97'					APP	CHK	BY
----------	------------------	--	--	--	--	-----	-----	----

(NOTE 1)

Definition of Operation Voltage(Vop)

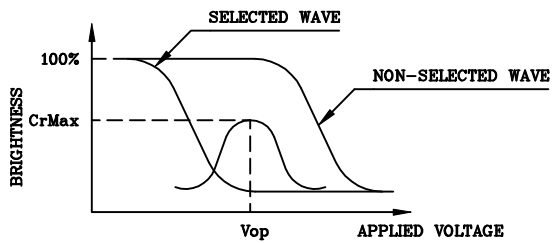

(positive type)

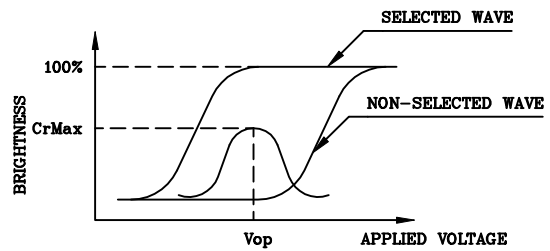

(negative type)

*Conditions

Viewing Angle : 0
 Frame Frequency : 70Hz
 Applied Waveform : 1/N duty, 1/a bias

(NOTE 2)

Definition of Response Time(Tr,Tf)

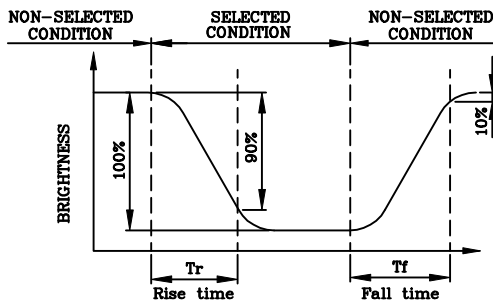

(positive type)

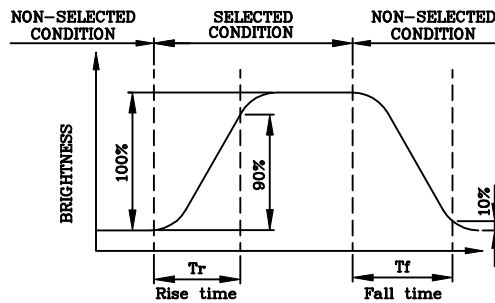

(negative type)

*Conditions

Operating Voltage : Vop
 Viewing Angle (θ,φ) : (0,0)
 Frame Frequency : 70Hz
 Applied Waveform : 1/N duty, 1/a bias

(NOTE 3)

Description of Measuring Equipment and Driving Waveforms

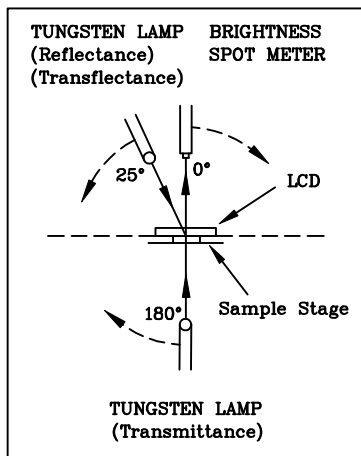

CONST.
 TEMP.
 CHAMBER

Multiplex Driving (1/N duty, 1/a bias)

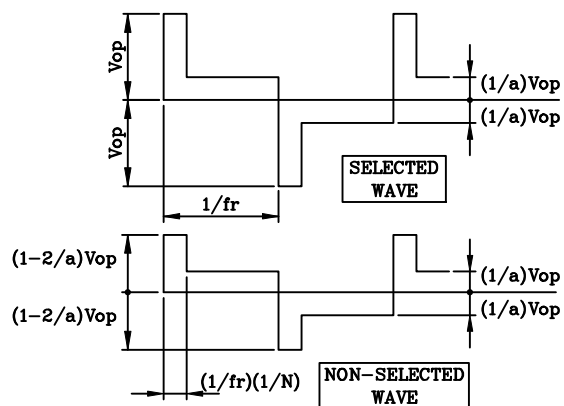

(NOTE 4)

Definition of Viewing Direction

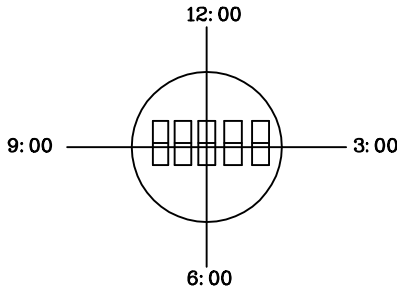

(NOTE 5)

Definition of Viewing Angle

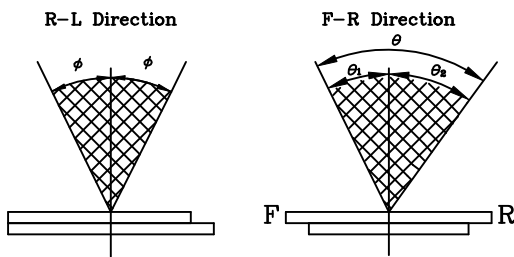

*Conditions

Operating Voltage : V_{op}
 Frame Frequency : 70Hz
 Applied Waveform : 1/N duty, 1/a bias
 Contrast Ratio : larger than 2

(NOTE 6)

Definition of Contrast Ratio (Cr)

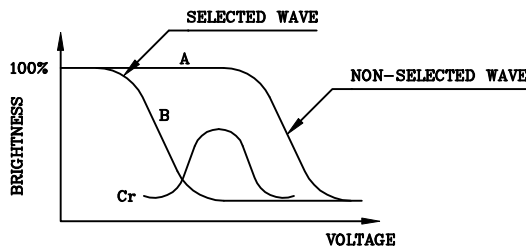

(positive type)

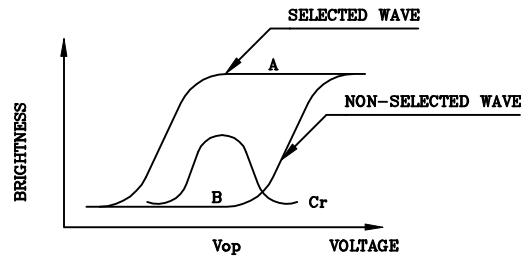

(negative type)

Contrast Ratio : $Cr=A/B$

*Conditions

Viewing Angle : 0
 Frame Frequency : 70Hz
 Applied Waveform : 1/N duty, 1/a bias

5. BLOCK DIAGRAM

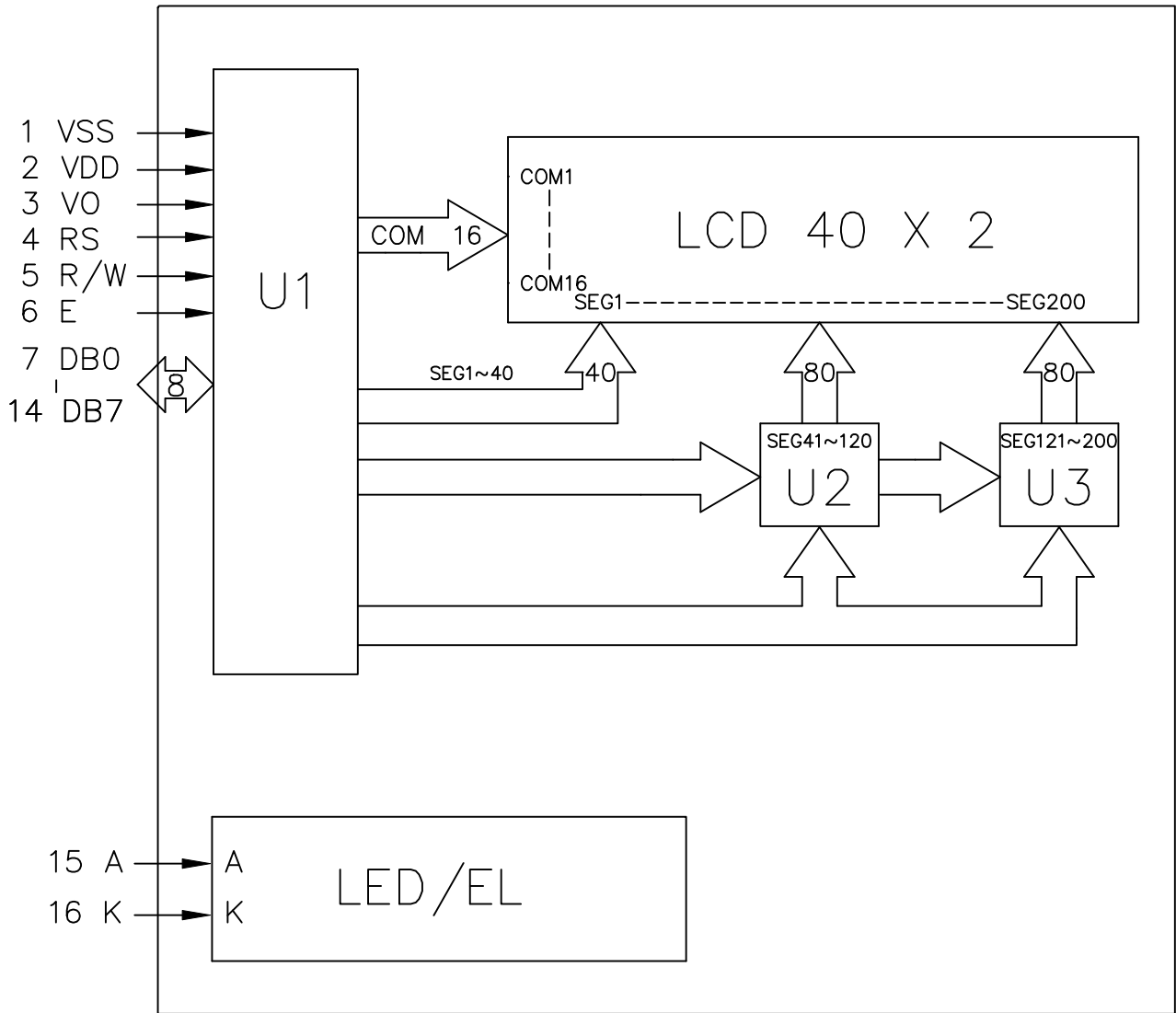

6. INTERNAL PIN CONNECTION

PinNo.	Symbol	Level	Function	
1	V _{SS}	—	0V	POWER SUPPLY
2	V _{DD}	—	+5V	
3	V _O	—	—	
4	RS	H/L	L: INSTRUCTION CODE INPUT H: DATA INPUT	
5	R/W	H/L	H: DATA READ (FROM LCM TO MPU) L: DATA WRITE (FROM MPU TO LCM)	
6	E	H, H->L	ENABLE SIGNAL	
7	DB0	H/L	DATA BUS LINE	
8	DB1	H/L		
9	DB2	H/L		
10	DB3	H/L		
11	DB4	H/L		
12	DB5	H/L		
13	DB6	H/L		
14	DB7	H/L	POWER SUPPLY FOR LED/EL	
15	A	—		
16	K	—		

7. POWER SUPPLY

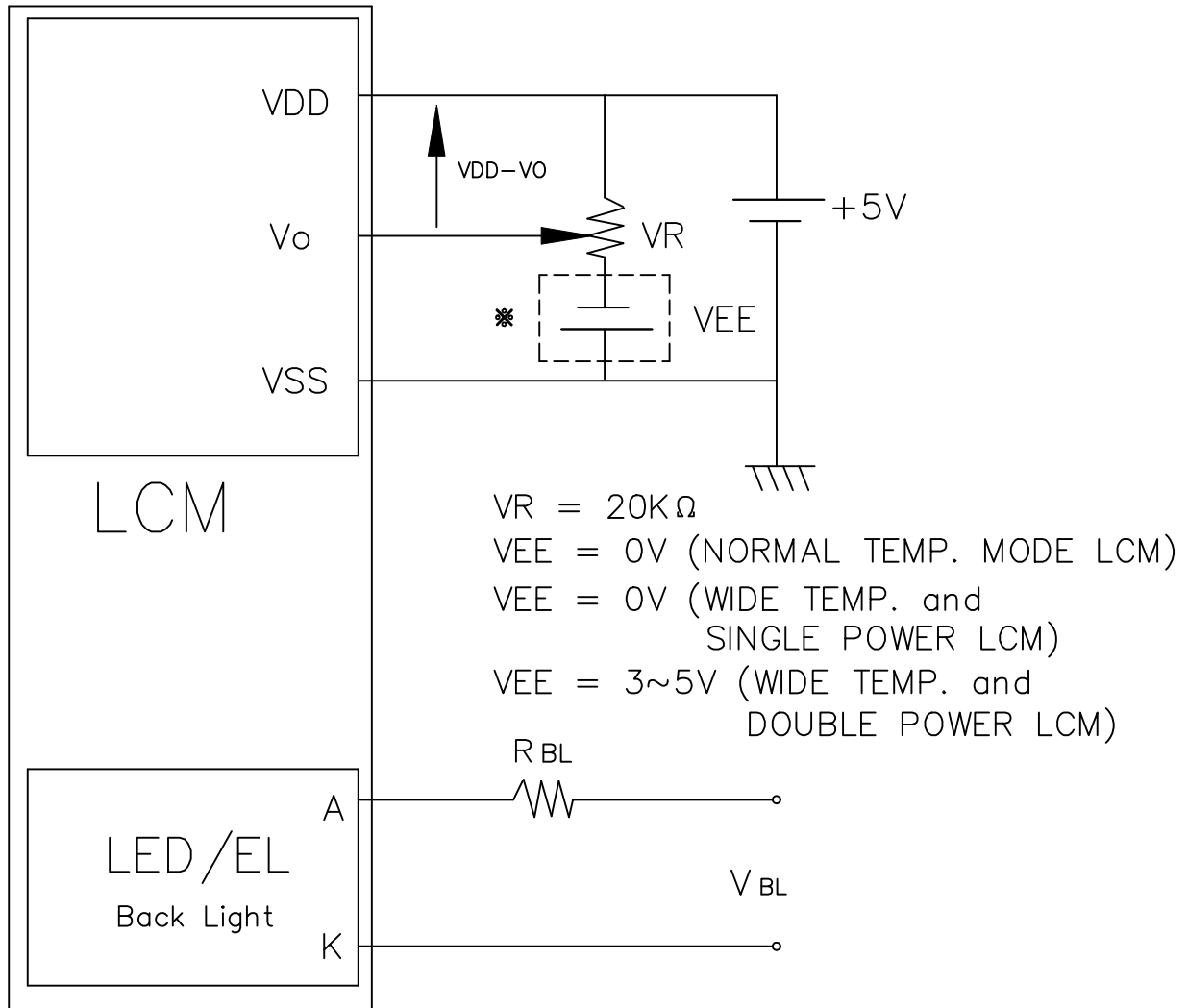

Recommended Value for R_{BL} and V_{BL}

ITEM Back Light Interface	R_{BL}		V_{BL}	
	LED	EL	LED	EL
16 PIN	0Ω	0Ω	$5V_{DC}$	$110V_{AC}$ $400Hz$

8. TIMING CHARACTERISTICS

Item	Symbol	Test Condition	Min.	Typ.	Max.	Unit
Enable cycle time	t_{cyc}	Fig.a, Fig.b	500	—	—	ns
Enable pulse width	PW_{EH}	Fig.a, Fig.b	230	—	—	ns
Enable rise/fall time	t_{Er}, t_{Ef}	Fig.a, Fig.b	—	—	20	ns
RS, R/W set up time	t_{AS}	Fig.a, Fig.b	40	—	—	ns
RS, R/W hold time	t_{H1}	Fig.a, Fig.b	10	—	—	ns
Data set up time	t_{DSW}	Fig.a	60	—	—	ns
Data output delay time	t_{DDR}	Fig.b	—	—	120	ns
Data write hold time	t_{H2}	Fig.a	10	—	—	ns
Data read hold time	t_{H2}	Fig.b	5	—	—	ns

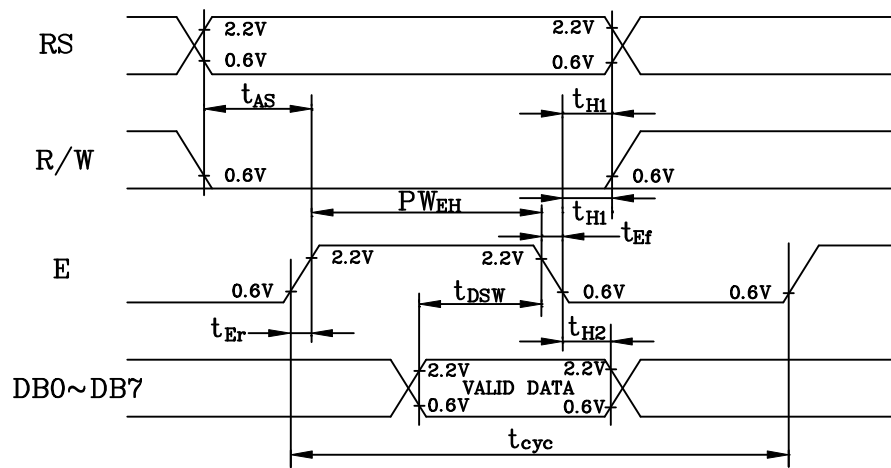

Fig.a Interface timing (data write)

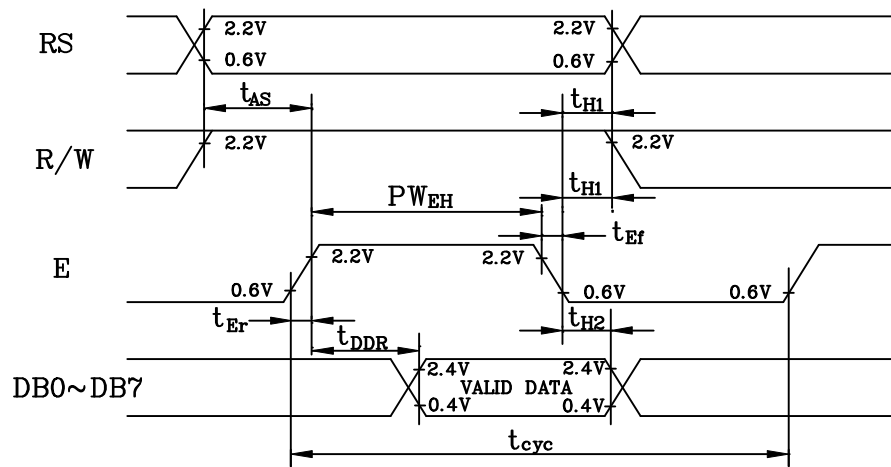

Fig.b Interface timing (data read)

9. CONTROL and DISPLAY COMMAND

COMMAND	RS	R/W	DB ₇	DB ₆	DB ₅	DB ₄	DB ₃	DB ₂	DB ₁	DB ₀	EXCUTION TIME (FOSC=250kHz)	REMARK																		
DISPLAY CLEAR	L	L	L	L	L	L	L	L	L	H	1.64ms																			
RETURN HOME	L	L	L	L	L	L	L	L	H	X	1.64ms	CURSOR MOVE TO FIRST DIGIT																		
ENTRY MODE SET	L	L	L	L	L	L	L	H	I/D	SH	40μS	<ul style="list-style-type: none"> I/D: SET CURSOR MOVE DIRECTION <table border="1"> <tr><td>I/D</td><td>H</td><td>INCREASE</td></tr> <tr><td>I/D</td><td>L</td><td>DECREASE</td></tr> </table> SH: SPECIFIES SHIFT OF DISPLAY <table border="1"> <tr><td>SH</td><td>H</td><td>DISPLAY IS SHIFTED</td></tr> <tr><td>SH</td><td>L</td><td>DISPLAY IS NOT SHIFTED</td></tr> </table> 	I/D	H	INCREASE	I/D	L	DECREASE	SH	H	DISPLAY IS SHIFTED	SH	L	DISPLAY IS NOT SHIFTED						
I/D	H	INCREASE																												
I/D	L	DECREASE																												
SH	H	DISPLAY IS SHIFTED																												
SH	L	DISPLAY IS NOT SHIFTED																												
DISPLAY ON/OFF	L	L	L	L	L	L	H	D	C	B	40μS	<ul style="list-style-type: none"> DISPLAY <table border="1"> <tr><td>D</td><td>H</td><td>DISPLAY ON</td></tr> <tr><td>D</td><td>L</td><td>DISPLAY OFF</td></tr> </table> CURSOR <table border="1"> <tr><td>C</td><td>H</td><td>CURSOR ON</td></tr> <tr><td>C</td><td>L</td><td>CURSOR OFF</td></tr> </table> BLINKING <table border="1"> <tr><td>B</td><td>H</td><td>BLINKING ON</td></tr> <tr><td>B</td><td>L</td><td>BLINKING OFF</td></tr> </table> 	D	H	DISPLAY ON	D	L	DISPLAY OFF	C	H	CURSOR ON	C	L	CURSOR OFF	B	H	BLINKING ON	B	L	BLINKING OFF
D	H	DISPLAY ON																												
D	L	DISPLAY OFF																												
C	H	CURSOR ON																												
C	L	CURSOR OFF																												
B	H	BLINKING ON																												
B	L	BLINKING OFF																												
SHIFT	L	L	L	L	L	H	S/C	R/L	X	X	40μS	<table border="1"> <tr><td>SC</td><td>H</td><td>DISPLAY SHIFT</td></tr> <tr><td>SC</td><td>L</td><td>CURSOR MOVE</td></tr> </table> <table border="1"> <tr><td>R/L</td><td>H</td><td>RIGHT SHIFT</td></tr> <tr><td>R/L</td><td>L</td><td>LEFT SHIFT</td></tr> </table>	SC	H	DISPLAY SHIFT	SC	L	CURSOR MOVE	R/L	H	RIGHT SHIFT	R/L	L	LEFT SHIFT						
SC	H	DISPLAY SHIFT																												
SC	L	CURSOR MOVE																												
R/L	H	RIGHT SHIFT																												
R/L	L	LEFT SHIFT																												
SET FUNCTION	L	L	L	L	H	DL	N	F	X	X	40μS	<table border="1"> <tr><td>DL</td><td>H</td><td>8 DITS INTERFACE</td></tr> <tr><td>DL</td><td>L</td><td>4 BITS INTERFACE</td></tr> </table> <table border="1"> <tr><td>N</td><td>H</td><td>2 LINE DISPLAY</td></tr> <tr><td>N</td><td>L</td><td>1 LINE DISPLAY</td></tr> </table> <table border="1"> <tr><td>F</td><td>H</td><td>5 X 10 DOTS</td></tr> <tr><td>F</td><td>L</td><td>5 X 7 DOTS</td></tr> </table>	DL	H	8 DITS INTERFACE	DL	L	4 BITS INTERFACE	N	H	2 LINE DISPLAY	N	L	1 LINE DISPLAY	F	H	5 X 10 DOTS	F	L	5 X 7 DOTS
DL	H	8 DITS INTERFACE																												
DL	L	4 BITS INTERFACE																												
N	H	2 LINE DISPLAY																												
N	L	1 LINE DISPLAY																												
F	H	5 X 10 DOTS																												
F	L	5 X 7 DOTS																												
SET CG RAM ADDRESS	L	L	L	H	CG RAM address (corresponds to cursor address)					40μS	CG RAM Data is sent and received after this setting																			
SET DD RAM ADDRESS	L	L	H	DD RAM address					40μS	DD RAM Data is sent and received after this setting																				
READ BUSY FLAG & ADDRESS	L	H	BF	Address Counter used for Both DD & CG RAM address					0μS	<table border="1"> <tr><td>BF</td><td>H</td><td>Busy</td></tr> <tr><td>BF</td><td>L</td><td>Ready</td></tr> </table> <ul style="list-style-type: none"> -Reads BF indication internal operating is being performed. -reads address counter contents 	BF	H	Busy	BF	L	Ready														
BF	H	Busy																												
BF	L	Ready																												
WRITE DATA	H	L	Write Data					46μS	Write data into DD or CG RAM																					
READ DATA	H	H	Read Data					46μS	Read data form DD or CGRAM																					

X : Don't care

10.DISPLAY PATTERN (40 x 2)

Display Data RAM address
 Versus Character Position

01	02	03	04	05	06	07	08	09	10	11	12	13	14	15	16	17	36	37	38	39	40	
00	01	02	03	04	05	06	07	08	09	0A	0B	0C	0D	0E	0F	10	23	24	25	26	27
40	41	42	43	44	45	46	47	48	49	4A	4B	4C	4D	4E	4F	50	63	64	65	66	67

11.CHARACTER FONT TABLE

	0	0	0	0	0	0	0	1	1	1	1	1	1
	0	0	0	1	1	1	1	0	0	1	1	1	1
	0	1	1	0	0	1	1	1	0	0	1	1	
	0	0	1	0	1	0	1	0	1	0	1	0	1
XXXX0000			0	0	P	`	P		-	9	3	0	0
XXXX0001		!	1	A	Q	a	q	.	ア	チ	△	△	Q
XXXX0010		"	2	B	R	b	r	「	イ	ツ	×	β	θ
XXXX0011		#	3	C	S	c	s	」	ウ	テ	ε	ε	ω
XXXX0100		\$	4	D	T	d	t	、	エ	ト	μ	μ	Ω
XXXX0101		%	5	E	U	e	u	・	オ	ナ	1	0	Ü
XXXX0110		&	6	F	V	f	v	ヲ	カ	ニ	ヨ	ρ	Σ
XXXX0111		'	7	G	W	g	w	フ	キ	ヌ	ラ	q	π
XXXX1000		(8	H	X	h	x	イ	ク	ネ	リ	ル	Σ
XXXX1001)	9	I	Y	i	y	ウ	ケ	ル	リ	ル	U
XXXX1010		*	:	J	Z	j	z	エ	コ	ハ	レ	i	〒
XXXX1011		+	;	K	[k	[オ	サ	ヒ	ロ	*	〒
XXXX1100		,	<	L	¥	l	l	カ	シ	フ	ワ	φ	〒
XXXX1101		-	=	M]	m]	ユ	ス	ハ	ン	も	÷
XXXX1110		.	>	N	^	n	^	ヨ	セ	ホ	°	ん	
XXXX1111		/	?	0	_	o	_	キ	ツ	マ	°	ö	■

12. RELIABILITY TEST

NO	ITEM	CONDITION			STANDARD	NOTE
1	High Temp. Storage	70°C	120HR		Appearance without defect	
2	Low Temp. Storage	-20°C	120HR		Appearance without defect	
3	High Temp. & High Humidity Storage	40°C 90%RH	120HR		Appearance without defect	
4	Thermal Shock	-20°C,30min → 25°C,5min → 60°C,30min → 25°C,5min (= 1 cycle)			Appearance without defect	5 cycles

13.LCD PRODUCT QUALITY STANDARD

(1) DISPLAY APPEARANCE

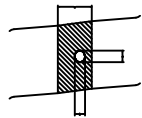
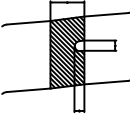
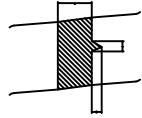
NO	ITEM	C R I T E R I A													
1.	INCLUSIONS (BLACK SPOT , WHITE SPOT , DUST)	(1) ROUND TYPE													
		<table border="1"> <thead> <tr> <th>DIAMETER mm (a*)</th> <th>NO. OF DEFECT*</th> </tr> </thead> <tbody> <tr> <td>a ≤ 0.20</td> <td>NEGLECT</td> </tr> <tr> <td>0.20 < a ≤ 0.35</td> <td>5 MAX</td> </tr> <tr> <td>0.35 < a</td> <td>NONE</td> </tr> </tbody> </table>	DIAMETER mm (a*)	NO. OF DEFECT*	a ≤ 0.20	NEGLECT	0.20 < a ≤ 0.35	5 MAX	0.35 < a	NONE					
DIAMETER mm (a*)	NO. OF DEFECT*														
a ≤ 0.20	NEGLECT														
0.20 < a ≤ 0.35	5 MAX														
0.35 < a	NONE														
		(2) LINEAR TYPE													
		<table border="1"> <thead> <tr> <th>LENGTH mm(L)</th> <th>WIDTH mm(W)</th> <th>NO. OF DEFECT</th> </tr> </thead> <tbody> <tr> <td>N A</td> <td>W ≤ 0.03</td> <td>NEGLECT</td> </tr> <tr> <td>L ≤ 3</td> <td>0.03 < W ≤ 0.08</td> <td>6</td> </tr> <tr> <td>3 < L</td> <td>0.08 < W</td> <td>NONE</td> </tr> </tbody> </table>	LENGTH mm(L)	WIDTH mm(W)	NO. OF DEFECT	N A	W ≤ 0.03	NEGLECT	L ≤ 3	0.03 < W ≤ 0.08	6	3 < L	0.08 < W	NONE	
LENGTH mm(L)	WIDTH mm(W)	NO. OF DEFECT													
N A	W ≤ 0.03	NEGLECT													
L ≤ 3	0.03 < W ≤ 0.08	6													
3 < L	0.08 < W	NONE													
2.	SCRATCH	1.SCRATCH ON PROTECTIVE FILM IS PERMITTED . 2.SCRATCH ON POLARIZER SHALL BE AS FOLLOW: (1) ROUND TYPE													
		<table border="1"> <thead> <tr> <th>DIAMETER mm (a*)</th> <th>NO. OF DEFECT*</th> </tr> </thead> <tbody> <tr> <td>a ≤ 0.15</td> <td>NEGLECT</td> </tr> <tr> <td>0.15 < a ≤ 0.20</td> <td>2 MAX</td> </tr> <tr> <td>0.20 < a</td> <td>NONE</td> </tr> </tbody> </table>	DIAMETER mm (a*)	NO. OF DEFECT*	a ≤ 0.15	NEGLECT	0.15 < a ≤ 0.20	2 MAX	0.20 < a	NONE					
DIAMETER mm (a*)	NO. OF DEFECT*														
a ≤ 0.15	NEGLECT														
0.15 < a ≤ 0.20	2 MAX														
0.20 < a	NONE														
		(2) LINEAR TYPE BE JUDGED BY 1.-(2) LINEAR TYPE													
3.	DENT	DIAMETER < 1.5mm													
4.	BUBBLE	NOT EXCEEDING 0.5mm AVERAGE DIAMETER IS ACCEPTABLE BETWEEN GLASS AND POLARIZING FILM.													
5.	PIN HOLE	(a+b)/2 ≤ 0.15 mm MAXIMUM NUMBER: IGNORED													
		0.15 < (a+b)/2 ≤ 0.20 MAXIMUM NUMBER: 10													
6.	DOT DEFECT	(a+b)/2 ≤ 0.20 mm MAXIMUM NUMBER: IGNORED													
		0.20 < (a+b)/2 ≤ 0.30 MAXIMUM NUMBER: 5 x = WIDTH													
															
															
7.	CONTRAST IRREGULARITY (SPOT)	DIAMETER SPEC.													
		<table border="1"> <thead> <tr> <th>NO. OF DEFECT*</th> </tr> </thead> <tbody> <tr> <td>a ≤ 0.50 mm</td> <td>NEGLECT</td> </tr> <tr> <td>0.50 < a ≤ 0.75</td> <td>5</td> </tr> <tr> <td>0.75 < a ≤ 1.00</td> <td>3</td> </tr> <tr> <td>1.00 < a</td> <td>NONE</td> </tr> </tbody> </table>	NO. OF DEFECT*	a ≤ 0.50 mm	NEGLECT	0.50 < a ≤ 0.75	5	0.75 < a ≤ 1.00	3	1.00 < a	NONE				
NO. OF DEFECT*															
a ≤ 0.50 mm	NEGLECT														
0.50 < a ≤ 0.75	5														
0.75 < a ≤ 1.00	3														
1.00 < a	NONE														
8.	DOT WIDTH	DESIGN WIDTH ± 15%													
9.	COLOR TONE AND UNIFORMITY	OBVIOUS UNEVEN COLOR IS NOT PERMITTED													

(2) NOTE:

• SAFETY

- 1.If the LCD panel breaks, be careful not to allow the liquid crystal to touch your skin.
- 2.If the liquid crystal touches your skin or clothes, please wash it off immediately by using soap and water.

• HANDLING

- 1.Prevent all contact with static electricity, which can damage the CMOS ICs. The module is packaged in a static-shielding bag to prevent damage during shipment, warehousing and removal from the shipping carton.
- 2.Do not remove the panel or frame from the module.
- 3.The polarizing plate on the front surface of the display is very fragile and easily scratched. The module is shipped with a protective liner which must be removed from the polarizing plate prior to assembly.
- 4.Do not wipe the polarizing plate with a dry cloth, as it may easily scratch the surface of polarizing plate.
- 5.Do not use ketonics solvent or aromatic solvent on the polarizing plate. Use a soft cloth soaked with plastic-lens cleaning solution.

• STORAGE

- 1.Store the panel or module in a dark place where the temperature is $25^{\circ}\text{C}\pm 5^{\circ}\text{C}$ and the humidity is below 65% RH.
- 2.Do not place the module near organics solvents or corrosive gases.
- 3.Do not crush, shake, or jolt the module.

• TERMS OF WARRANTY

- 1.Acceptance inspection period
The inspection period is within one month after the arrival of the contracted goods at the buyer's factory site.
- 2.Applicable warranty period
The warranty period is within twelve months from the date of invoice under normal usage and storage conditions.

• TYPICAL OPERATING LIFETIME OF BACKLIGHT

- LED : 50,000HR
EL : 5,000HR
CCFT : 10,000HR

REV/DATE	R0/ 09.17.97'					APP	CHK	BY
----------	------------------	--	--	--	--	-----	-----	----

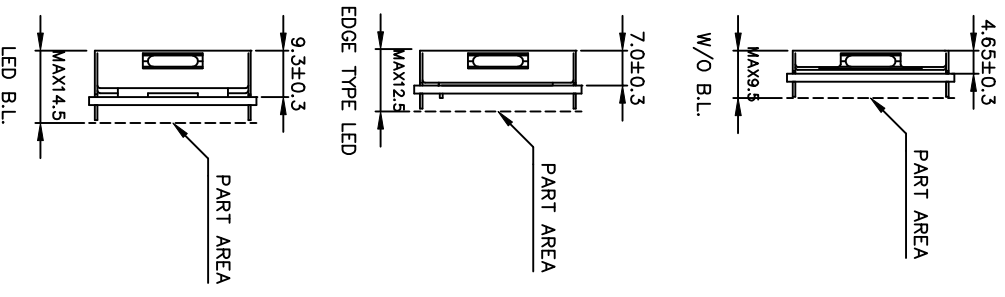
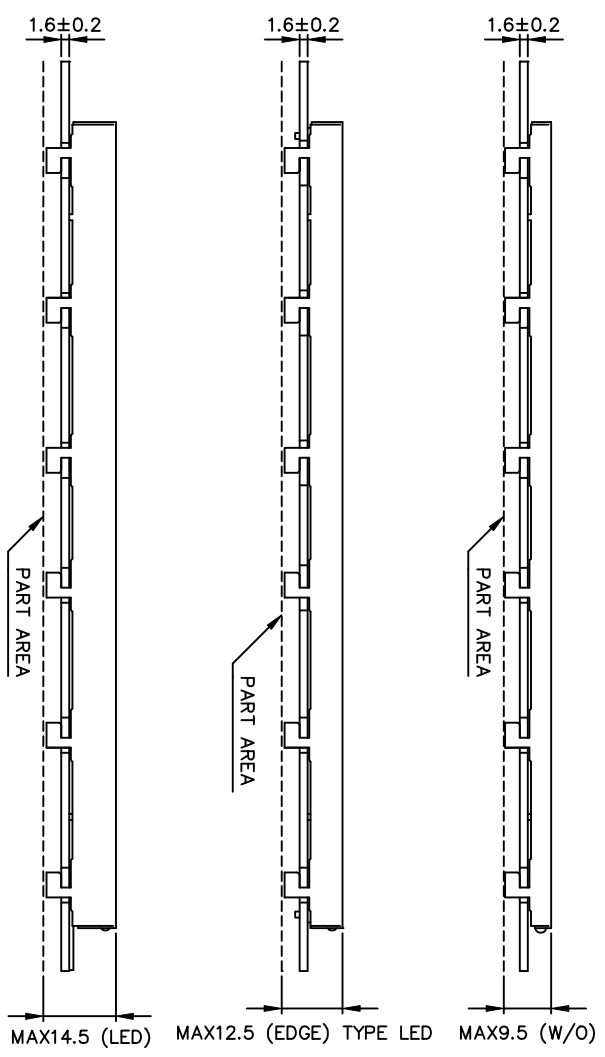
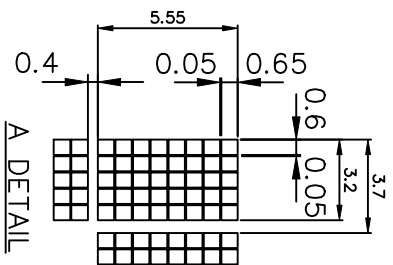
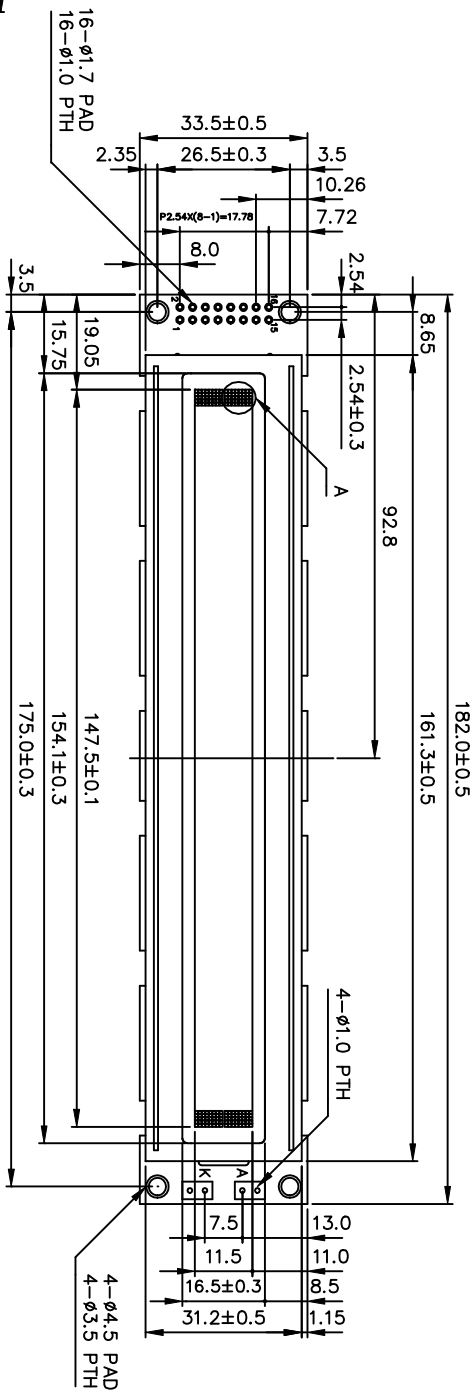

PinNo.	Symbol	Level	Function
1	VSS	-	0V
2	VDD	-	+5V Power Supply
3	VO	-	-
4	RS	H/L	TRANSDUCTION CODE INPUT
5	R/W	H/L	HORIZONTAL WRITE (FROM LSW TO LSW)
6	E	H/L	ENABLE SIGNAL
7	DB0	H/L	DATA BUS LINE
8	DB1	H/L	
9	DB2	H/L	
10	DB3	H/L	
11	DB4	H/L	
12	DB5	H/L	
13	DB6	H/L	
14	DB7	H/L	
15	A	-	+5V Power Supply for LED
16	K	-	0V

Note :
1. Resolution : 40X2 Characters
2. Character Format : 5X8 Dots

產品編號	LM_J3_075_E	NAME	DATE
APPROVE			
CHECK			
DESIGN			
DRAW	MAY PING	86.01.08	

南亞塑膠工業股份有限公司
NAN YA PLASTICS CORPORATION

製圖

TITLE

DWG-NO MXXB075XX Rev.A

UNIT : mm

SCALE :