

NAN YA PLASTICS CORP. ELEC. MATERIALS DIV. LCD DEPARTMENT	SPECIFICATION	SPEC. NO. : LM025-0 DATE : Mar. 24, 1998 SHEET NO. : 1/19
---	---------------	---

U.S. MARKETING ARM:

MARK PRODUCTS CORPORATION  
 800 N. EDGEWOOD AVENUE  
 WOOD DALE, IL 60191  
 TEL: 630-787-9089  
 FAX: 630-787-9015

SPECIFICATION OF  
 24x2 LCD MODULE  
 PRODUCT NO.: LM\_B3\_025\_2\_

SPEC. NO.: LM025-0

APPROVED BY

EDITED ON : Mar.24, 1998

SALES MANAGER	DESIGN MANAGER	PERSON IN CHARGE

REV/DATE	RO/ 03.24.98'					APP	CHK	BY
----------	------------------	--	--	--	--	-----	-----	----

# 1. MECHANICAL DATA

- (1) Product No. LM\_B3\_025\_2\_
- (2) Module Size 118.0 (W)mm x 36.0 (H)mm x MAX9.5 (D)mm  
(W/O,EL B.L.)  
118.0 (W)mm x 36.0 (H)mm x MAX14.5 (D)mm  
(LED B.L.)
- (3) Dot Size 0.60 (W)mm x 0.65 (H)mm
- (4) Dot Pitch 0.65 (W)mm x 0.70 (H)mm
- (5) Number of Characters 24 (W) x 2 (H)Characters
- (6) Character Format 5 (W) x 8 (H)Dots
- (7) Duty 1/16
- (8) LCD Display Mode STN: Gray Mode  Yellow Mode  Blue Mode  
FSTN: Black and White(Normal White/Positive Image)  
 Black and White(Normal Black/Negative Image)  
Rear Polarizer: Reflective  Transflective  Transmissive
- (9) Viewing Direction  6 O'clock  12 O'clock  \_\_\_O'clock
- (10) Backlight  W/O  EL B/L  LED B/L
- (11) Weight W/O B/L: 39 g(Approx.)  
EL B/L: 43 g(Approx.)  
LED B/L: 56 g(Approx.)

Note :

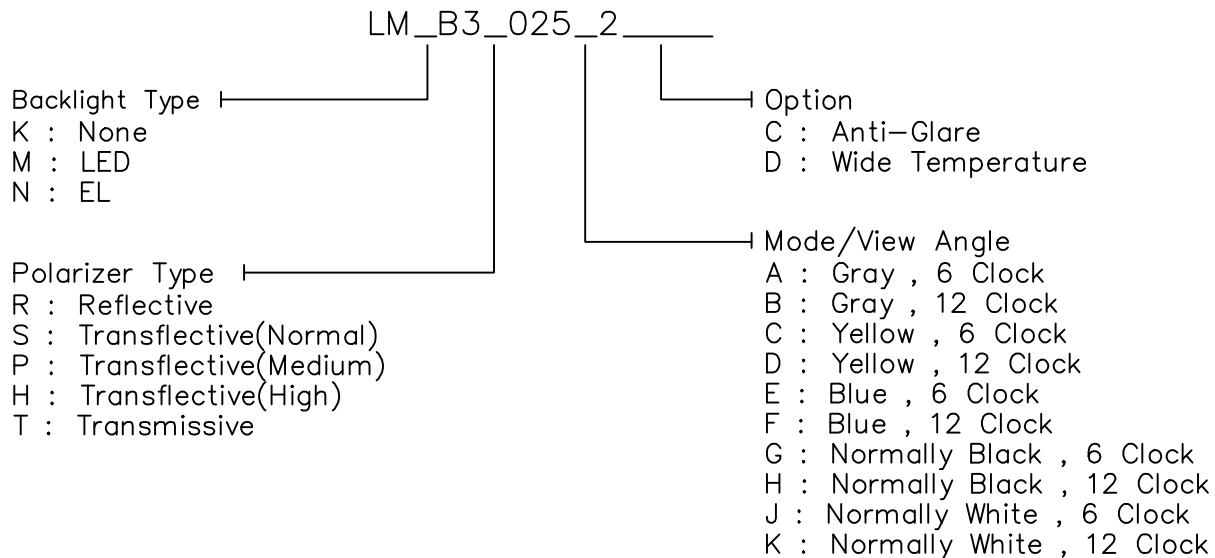

## 2. ABSOLUTE MAXIMUM RATINGS

### (1) ELECTRICAL ABSOLUTE RATINGS

V<sub>SS</sub>=0V

	SYMBOL	MIN	MAX	UNIT	COMMENT
Power Supply for Logic	VDD-VSS	-0.3	6.5	V	
Input Voltage	V <sub>I</sub>	-0.3	VDD	V	
Static Electricity	-	-	-		Note 1

Note 1 LCM should be grounded during handling LCM.

### (2) ENVIRONMENTAL ABSOLUTE MAXIMUM RATINGS

ITEM	NORMAL TEMP.				WIDE TEMP.			
	OPERATING		STORAGE		OPERATING		STORAGE	
	MIN.	MAX.	MIN.	MAX.	MIN.	MAX.	MIN.	MAX.
Ambient Temperature	0	50	-20	70	-20	70	-30	80
Humidity (Without Condensation)	Note 1,3		Note 2,3		Note 3,4		Note 3,5	

Note 1 Ta ≤ 50°C : 85%RH max

Ta > 50°C : Absolute humidity must be lower  
 than the humidity of 85%RH at 50°C

Note 2 Ta at -20°C will be < 48hrs, at 70°C will be < 120hrs

Note 3 Background color changes slightly depending on ambient temperature.  
 This phenomenon is reversible.

Note 4 Ta ≤ 70°C : 75%RH max

Ta > 70°C : Absolute humidity must be lower  
 than the humidity of 75%RH at 70°C

Note 5 Ta at -30°C will be < 48hrs, at 80°C will be < 120hrs

### 3. ELECTRICAL CHARACTERISTICS

( VDD = 5V±10% )

ITEM	SYMBOL	CONDITION	MIN.	TYP.	MAX.	UNIT	
Input Voltage	VIH	H level	0.8VDD	-	VDD	V	
	VIO	L level	0	-	0.2VDD	V	
Recommended LC Driving Voltage (NORMAL TEMP. LCM)	VDD-V0	Bias= 1/5	0°C	-	4.8	5.4	V
			25°C	4.2	4.7	5.2	
			50°C	3.8	4.3	-	
Recommended LC Driving Voltage (WIDE TEMP. LCM)	VDD-V0	Bias= 1/5	-20°C	5.9	6.4	7.2	V
			0°C	5.7	6.4	7.2	
			25°C	5.7	6.2	6.8	
			50°C	5.5	5.9	6.5	
			70°C	5.3	5.5	6.1	
Power Supply Current	IDD	VDD = 5.0V	-	-	2.8	mA	
LED Power Supply Current	ILED	VBL = 5Vdc (RBL = 5Ω) (RBL = 10Ω)	-	153 100	-	mA	
EL Power Supply Current	IEL	VBL = 110Vac 400Hz	-	-	5.0	mA	

# 4. OPTICAL CHARACTERISTICS

FOR NORMAL TEMPERATURE MODE LCM

AT Vop

ITEM MODE		Cr(Contrast Ratio)		$\theta$ (Viewing Angle)		$\phi$ (Viewing Angle)	
		25℃		25℃		25℃	
		MIN.	TYP.	MIN.	TYP.	MIN.	TYP.
R	A	3.0	4.0	40	65	25	35
	C	5.0	8.0	50	70	28	38
	J						
S	A	3.0	4.0	35	60	20	32
	C	4.0	7.0	45	65	25	35
	J						
T	E	2.5	3.0	30	50	20	30
	G	2.5	5.0	30	50	20	30
NOTE		NOTE6		NOTE5			

AT  $\phi=0^\circ$   $\theta=0^\circ$

ITEM	SYMBOL	CONDITION	MIN.	TYP.	MAX.	UNIT	NOTE
Response Time (rise)	Tr	0℃	-	460	900	ms	NOTE 2
		25℃	-	110	220		
		50℃	-	65	130		
Response Time (fall)	Tf	0℃	-	420	800	ms	NOTE 2
		25℃	-	140	250		
		50℃	-	90	155		

NOTE :

- R: REFLECTIVE
- S: TRANFLECTIVE
- T: TRANSMISSIVE
- A: GRAY
- C: YELLOW
- E: BLUE
- G: NORMALLY BLACK
- J: NORMALLY WHITE

# 4-1. OPTICAL CHARACTERISTICS

FOR WIDE TEMPERATURE MODE LCM

AT Vop

ITEM MODE		Cr(Contrast Ratio)		$\theta$ (Viewing Angle)		$\phi$ (Viewing Angle)	
		25℃		25℃		25℃	
		MIN.	TYP.	MIN.	TYP.	MIN.	TYP.
R	A	3.5	4.3	40	65	25	35
	C	5.5	9.0	50	70	28	38
	J						
S	A	3.2	4.1	35	60	20	32
	C	4.5	7.5	45	65	25	35
	J						
T	E	2.7	3.3	30	50	20	30
	G	3.0	5.5	30	50	20	30
NOTE		NOTE6		NOTE5			

AT  $\phi=0^\circ$   $\theta=0^\circ$

ITEM	SYMBOL	CONDITION	MIN.	TYP.	MAX.	UNIT	NOTE
Response Time (rise)	Tr	-20℃	-	1500	3000	ms	NOTE 2
		0℃	-	270	540		
		25℃	-	120	240		
		50℃	-	70	140		
		70℃	-	65	130		
Response Time (fall)	Tf	-20℃	-	2000	3500	ms	NOTE 2
		0℃	-	310	580		
		25℃	-	100	220		
		50℃	-	50	120		
		70℃	-	40	105		

NOTE :

R: REFLECTIVE  
S: TRANSFLECTIVE  
T: TRANSMISSIVE  
A: GRAY

C: YELLOW  
E: BLUE  
G: NORMALLY BLACK  
J: NORMALLY WHITE

REV/DATE	R0/ 03.24.98'					APP	CHK	BY
----------	------------------	--	--	--	--	-----	-----	----

(NOTE 1)

Definition of Operation Voltage(Vop)

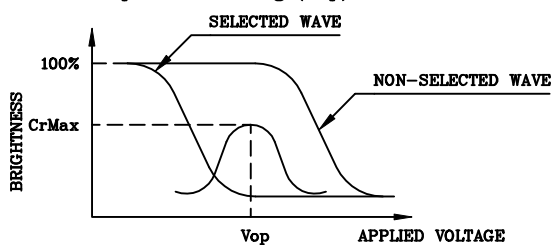

(positive type)

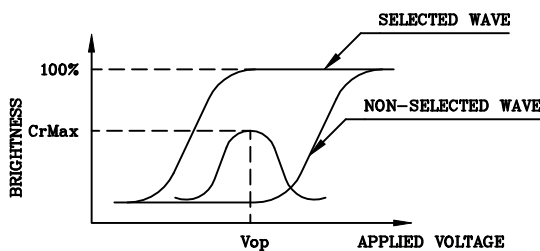

(negative type)

\*Conditions

Viewing Angle : 0  
 Frame Frequency : 70Hz  
 Applied Waveform : 1/N duty, 1/a bias

(NOTE 2)

Definition of Response Time(Tr,Tf)

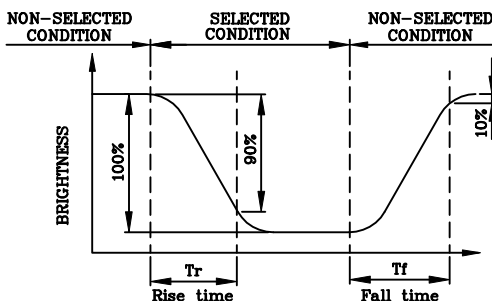

(positive type)

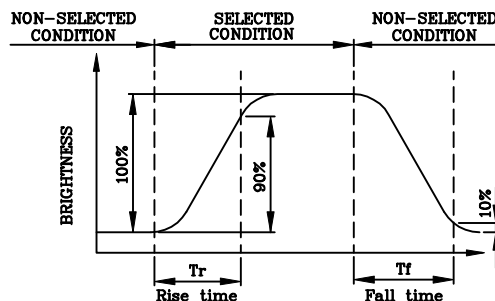

(negative type)

\*Conditions

Operating Voltage : Vop  
 Viewing Angle (θ,φ) : (0,0)  
 Frame Frequency : 70Hz  
 Applied Waveform : 1/N duty, 1/a bias

(NOTE 3)

Description of Measuring Equipment and Driving Waveforms

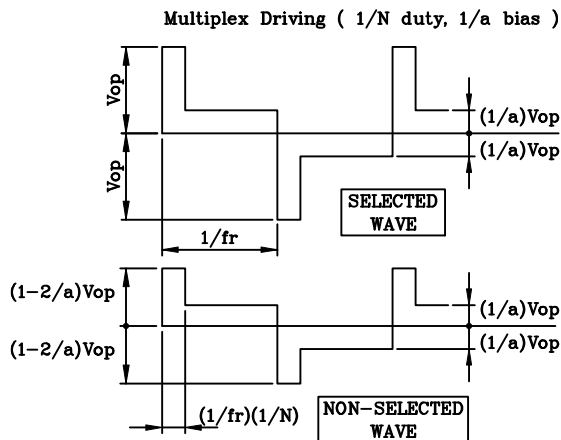
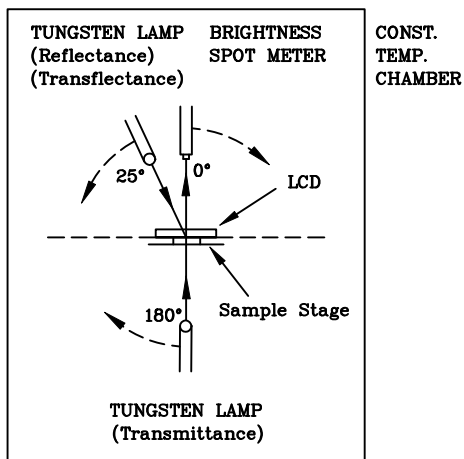

(NOTE 4)

Definition of Viewing Direction

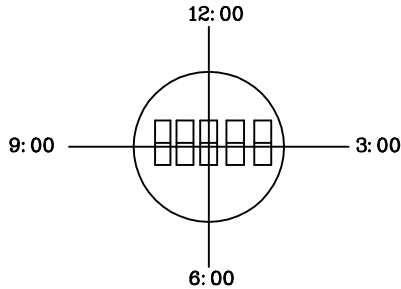

(NOTE 5)

Definition of Viewing Angle

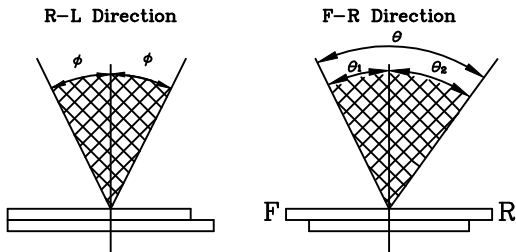

$$\theta = \theta_1 + \theta_2$$

\*Conditions

Operating Voltage :  $V_{op}$   
 Frame Frequency : 70Hz  
 Applied Waveform : 1/N duty, 1/a bias  
 Contrast Ratio : larger than 2

(NOTE 6)

Definition of Contrast Ratio (Cr)

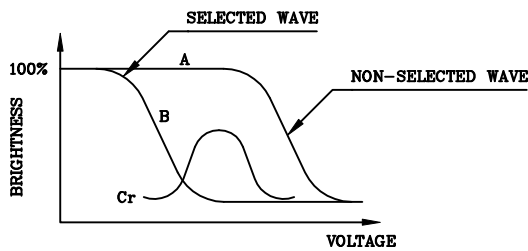

(positive type)

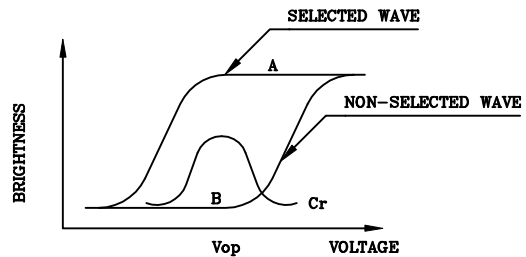

(negative type)

$$\text{Contrast Ratio} : Cr = A/B$$

\*Conditions

Viewing Angle : 0  
 Frame Frequency : 70Hz  
 Applied Waveform : 1/N duty, 1/a bias



# 5. BLOCK DIAGRAM

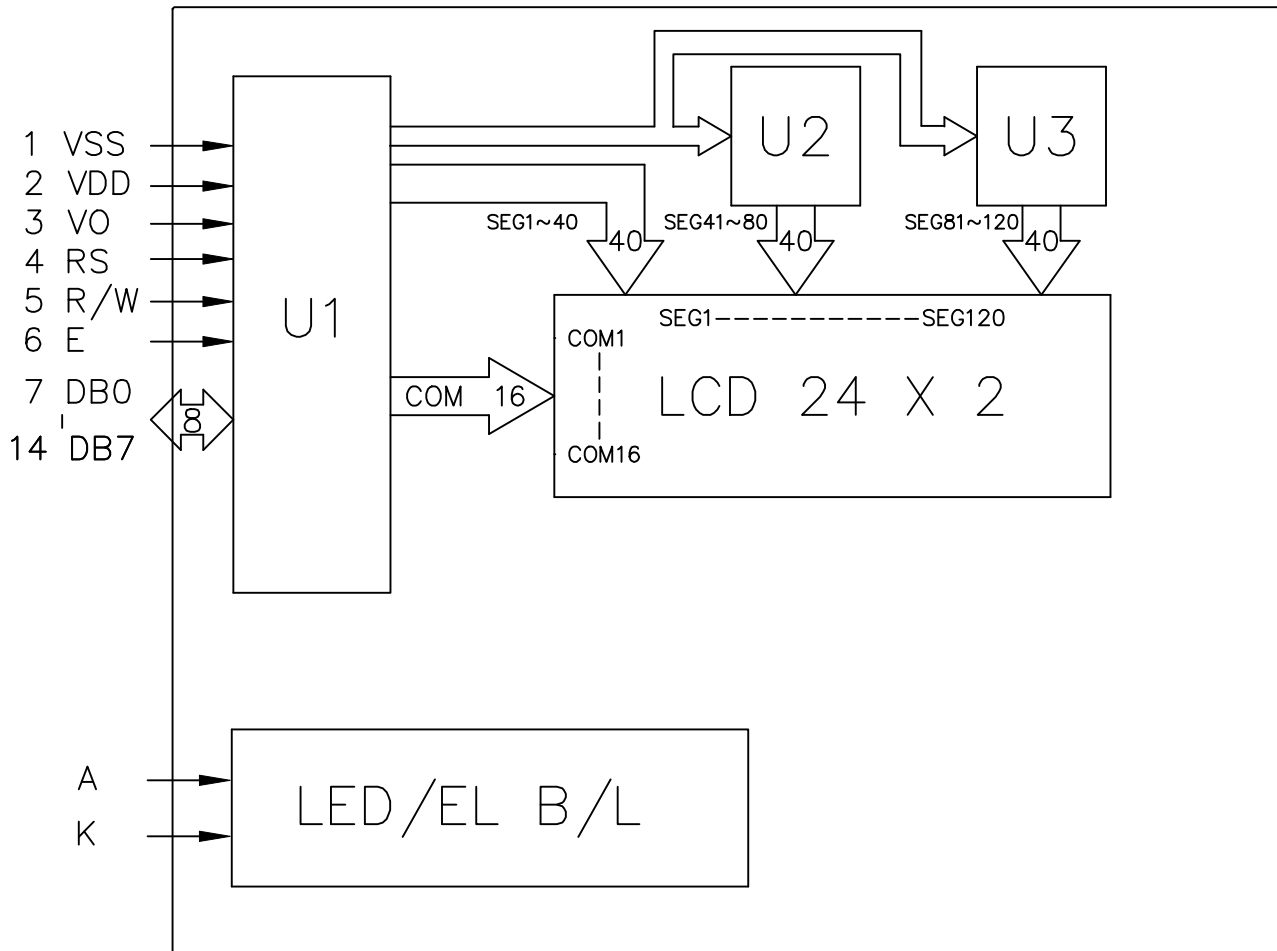

## 6. INTERNAL PIN CONNECTION

PinNo.	Symbol	Level	Function	
1	V <sub>SS</sub>	—	0V	POWER SUPPLY
2	V <sub>DD</sub>	—	+5V	
3	V <sub>0</sub>	—	—	
4	RS	H/L	L: INSTRUCTION CODE INPUT H: DATA INPUT	
5	R/W	H/L	H: DATA READ (FROM LCM TO MPU) L: DATA WRITE (FROM MPU TO LCM)	
6	E	H, H->L	ENABLE SIGNAL	
7	DB0	H/L	DATA BUS LINE	
8	DB1	H/L		
9	DB2	H/L		
10	DB3	H/L		
11	DB4	H/L		
12	DB5	H/L		
13	DB6	H/L		
14	DB7	H/L		

# 7. POWER SUPPLY

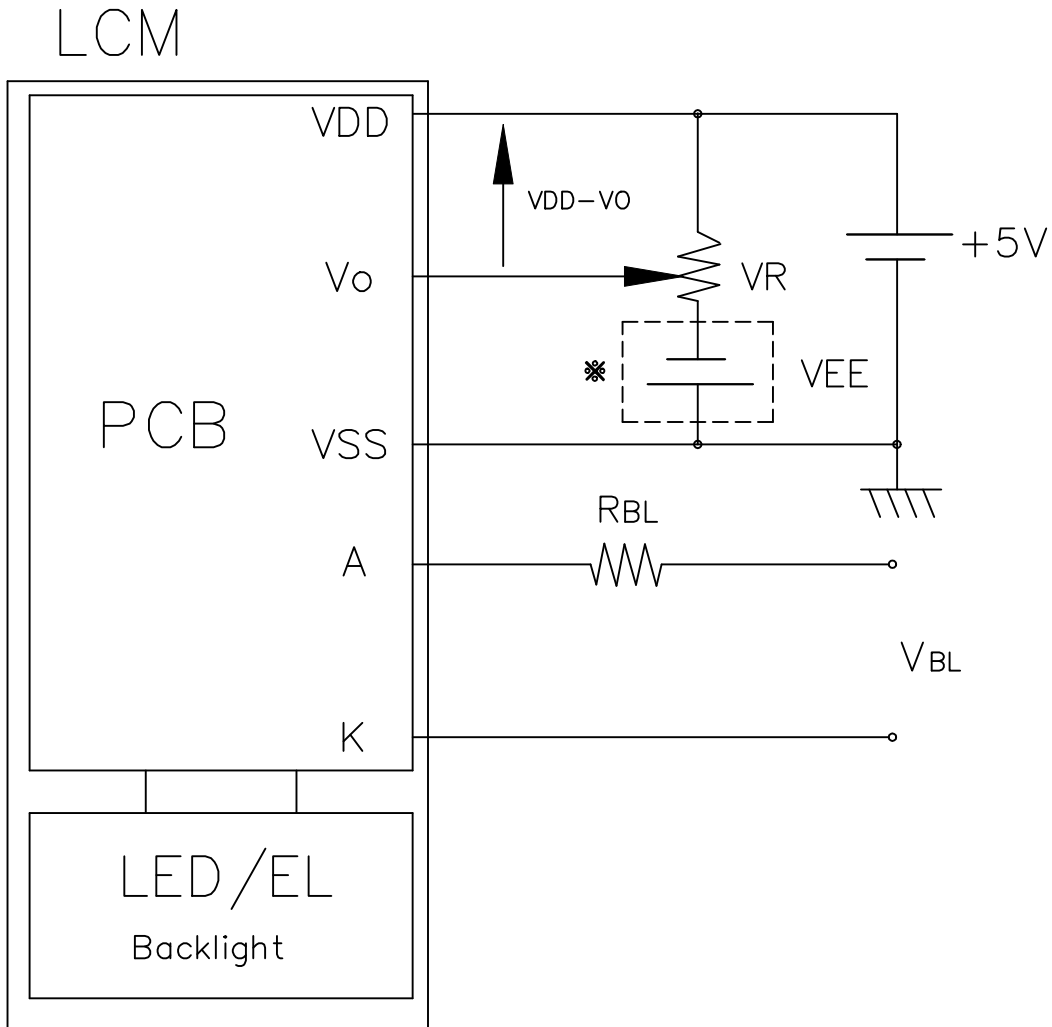

$VR = 20K\Omega$ (Variable)

$VEE = 0V$ (NORMAL TEMP. MODE LCM)

\*  $VEE = 3\sim 5V$ (WIDE TEMP. MODE LCM)

Recommended Value for RBL and VBL

ITEM	RBL		VBL	
	LED	EL	LED	EL
Back Light				
Interface				
A,K Pad	5Ω	0Ω	5V	110V <sub>ac</sub> 400Hz
	10Ω			

## 8. TIMING CHARACTERISTICS

Item	Symbol	Test Condition	Min.	Typ.	Max.	Unit
Enable cycle time	$t_{cyc}$	Fig. a, Fig. b	500	-	-	ns
Enable pulse width	$PW_{EH}$	Fig. a, Fig. b	230	-	-	ns
Enable rise/fall time	$t_{Er}, t_{Ef}$	Fig. a, Fig. b	-	-	20	ns
RS, R/W set up time	$t_{AS}$	Fig. a, Fig. b	40	-	-	ns
RS, R/W hold time	$t_{H1}$	Fig. a, Fig. b	10	-	-	ns
Data set up time	$t_{DSW}$	Fig. a	60	-	-	ns
Data output delay time	$t_{DDR}$	Fig. b	-	-	120	ns
Data write hold time	$t_{H2}$	Fig. a	10	-	-	ns
Data read hold time	$t_{H2}$	Fig. b	5	-	-	ns

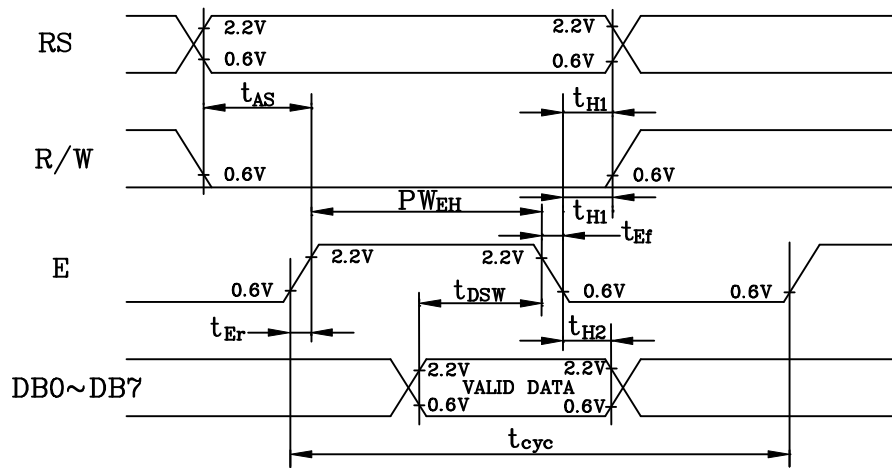

Fig. a Interface timing (data write)

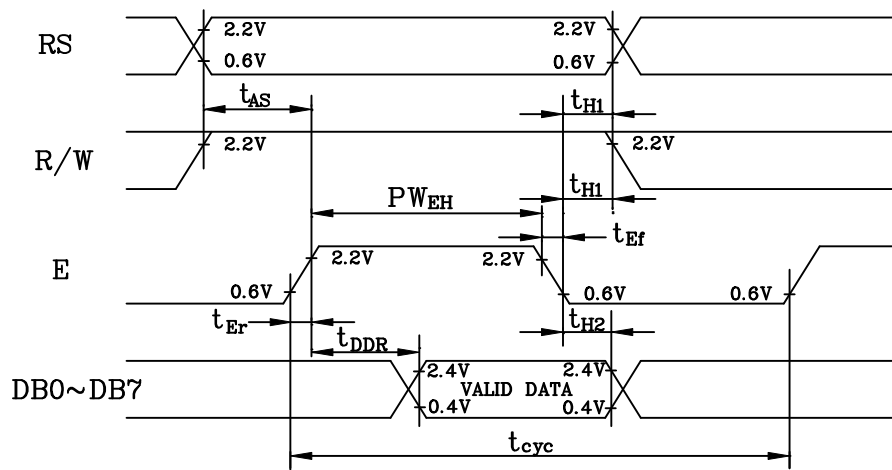

Fig. b Interface timing (data read)

## 9.CONTROL and DISPLAY COMMAND

COMMAND	RS	R/W	DB <sub>7</sub>	DB <sub>6</sub>	DB <sub>5</sub>	DB <sub>4</sub>	DB <sub>3</sub>	DB <sub>2</sub>	DB <sub>1</sub>	DB <sub>0</sub>	EXCUTION TIME (FOSC=250kHz)	REMARK																		
DISPLAY CLEAR	L	L	L	L	L	L	L	L	L	H	1.64ms																			
RETURN HOME	L	L	L	L	L	L	L	L	H	X	1.64ms	CURSOR MOVE TO FIRST DIGIT																		
ENTRY MODE SET	L	L	L	L	L	L	L	H	I/D	SH	40 μS	•I/D: SET CURSOR MOVE DIRECTION <table border="1"> <tr><td>I/D</td><td>H</td><td>INCREASE</td></tr> <tr><td>I/D</td><td>L</td><td>DECREASE</td></tr> </table> •SH: SPECIFIES SHIFT OF DISPLAY <table border="1"> <tr><td>SH</td><td>H</td><td>DISPLAY IS SHIFTED</td></tr> <tr><td>SH</td><td>L</td><td>DISPLAY IS NOT SHIFTED</td></tr> </table>	I/D	H	INCREASE	I/D	L	DECREASE	SH	H	DISPLAY IS SHIFTED	SH	L	DISPLAY IS NOT SHIFTED						
I/D	H	INCREASE																												
I/D	L	DECREASE																												
SH	H	DISPLAY IS SHIFTED																												
SH	L	DISPLAY IS NOT SHIFTED																												
DISPLAY ON/OFF	L	L	L	L	L	L	H	D	C	B	40 μS	•DISPLAY <table border="1"> <tr><td>D</td><td>H</td><td>DISPLAY ON</td></tr> <tr><td>D</td><td>L</td><td>DISPLAY OFF</td></tr> </table> •CURSOR <table border="1"> <tr><td>C</td><td>H</td><td>CURSOR ON</td></tr> <tr><td>C</td><td>L</td><td>CURSOR OFF</td></tr> </table> •BLINKING <table border="1"> <tr><td>B</td><td>H</td><td>BLINKING ON</td></tr> <tr><td>B</td><td>L</td><td>BLINKING OFF</td></tr> </table>	D	H	DISPLAY ON	D	L	DISPLAY OFF	C	H	CURSOR ON	C	L	CURSOR OFF	B	H	BLINKING ON	B	L	BLINKING OFF
D	H	DISPLAY ON																												
D	L	DISPLAY OFF																												
C	H	CURSOR ON																												
C	L	CURSOR OFF																												
B	H	BLINKING ON																												
B	L	BLINKING OFF																												
SHIFT	L	L	L	L	L	H	S/C	R/L	X	X	40 μS	<table border="1"> <tr><td>SC</td><td>H</td><td>DISPLAY SHIFT</td></tr> <tr><td>SC</td><td>L</td><td>CURSOR MOVE</td></tr> </table> <table border="1"> <tr><td>R/L</td><td>H</td><td>RIGHT SHIFT</td></tr> <tr><td>R/L</td><td>L</td><td>LEFT SHIFT</td></tr> </table>	SC	H	DISPLAY SHIFT	SC	L	CURSOR MOVE	R/L	H	RIGHT SHIFT	R/L	L	LEFT SHIFT						
SC	H	DISPLAY SHIFT																												
SC	L	CURSOR MOVE																												
R/L	H	RIGHT SHIFT																												
R/L	L	LEFT SHIFT																												
SET FUNCTION	L	L	L	L	H	DL	N	F	X	X	40 μS	<table border="1"> <tr><td>DL</td><td>H</td><td>8 DITS INTERFACE</td></tr> <tr><td>DL</td><td>L</td><td>4 BITS INTERFACE</td></tr> </table> <table border="1"> <tr><td>N</td><td>H</td><td>2 LINE DISPLAY</td></tr> <tr><td>N</td><td>L</td><td>1 LINE DISPLAY</td></tr> </table> <table border="1"> <tr><td>F</td><td>H</td><td>5 X 10 DOTS</td></tr> <tr><td>F</td><td>L</td><td>5 X 7 DOTS</td></tr> </table>	DL	H	8 DITS INTERFACE	DL	L	4 BITS INTERFACE	N	H	2 LINE DISPLAY	N	L	1 LINE DISPLAY	F	H	5 X 10 DOTS	F	L	5 X 7 DOTS
DL	H	8 DITS INTERFACE																												
DL	L	4 BITS INTERFACE																												
N	H	2 LINE DISPLAY																												
N	L	1 LINE DISPLAY																												
F	H	5 X 10 DOTS																												
F	L	5 X 7 DOTS																												
SET CG RAM ADDRESS	L	L	L	H	CG RAM address (corresponds to cursor address)					40 μS	CG RAM Data is sent and received after this setting																			
SET DD RAM ADDRESS	L	L	H	DD RAM address					40 μS	DD RAM Data is sent and received after this setting																				
READ BUSY FLAG & ADDRESS	L	H	BF	Address Counter used for Both DD & CG RAM address					0 μS	<table border="1"> <tr><td>BF</td><td>H</td><td>Busy</td></tr> <tr><td>BF</td><td>L</td><td>Ready</td></tr> </table> -Reads BF indication internal operating is being performed. -reads address counter contents	BF	H	Busy	BF	L	Ready														
BF	H	Busy																												
BF	L	Ready																												
WRITE DATA	H	L	Write Data					46 μS	Write data into DD or CG RAM																					
READ DATA	H	H	Read Data					46 μS	Read data form DD or CGRAM																					

X : Don't care

REV/DATE

R0/  
03.24.98'

APP

CHK

BY

# 10.DISPLAY PATTERN

Display Data RAM address

Versus Character Position

1	00	01	02	03	04	05	06	07	08	09	0A	0B	0C	0D	0E	0F	10	11	12	13	14	15	16	17	18	19	20	21	22	23	24
	40	41	42	43	44	45	46	47	48	49	4A	4B	4C	4D	4E	4F	50	51	52	53	54	55	56	57							

24 x 2 Display Pattern

# 11.CHARACTER FONT TABLE

	0	0	0	0	0	0	0	1	1	1	1	1	1
	0	0	0	1	1	1	1	0	0	1	1	1	1
	0	1	1	0	0	1	1	1	1	0	0	1	1
	0	0	1	0	1	0	1	0	1	0	1	0	1
XXXXX00000			0	0	P	`	P		-	夕	ミ	Ω	P
XXXXX00011		!	1	A	Q	a	q	。	ア	チ	△	△	Q
XXXXX00110		"	2	B	R	b	r	「	イ	ツ	×	β	θ
XXXXX00111		#	3	C	S	c	s	」	ウ	テ	ε	ε	∞
XXXXX01100		\$	4	D	T	d	t	、	エ	ト	†	Ω	Ω
XXXXX01101		%	5	E	U	e	u	・	オ	ナ	1	ε	Ü
XXXXX01110		&	6	F	V	f	v	ヲ	カ	ニ	ヨ	ρ	Σ
XXXXX01111		'	7	G	W	g	w	フ	キ	ヌ	ラ	Q	π
XXXXX10000		(	8	H	X	h	x	イ	ク	ネ	リ	」	×
XXXXX10011		)	9	I	Y	i	y	ウ	ケ	ル	」	」	U
XXXXX10110		*	:	J	Z	j	z	エ	コ	ン	レ	i	千
XXXXX10111		+	;	K	[	k	[	オ	サ	ヒ	ロ	*	万
XXXXX11100		,	<	L	¥	l	l	カ	シ	フ	フ	Φ	円
XXXXX11101		-	=	M	]	m	]	ユ	ズ	へ	ン	も	÷
XXXXX11110		.	>	N	^	n	→	ヨ	セ	ホ	°	ん	
XXXXX11111		/	?	0	_	o	←	ツ	マ	°	ö	■	

## 12.RELIABILITY TEST

NO	ITEM	CONDITION			STANDARD	NOTE
1	High Temp. Storage	70°C	120HR		Appearance without defect	
2	Low Temp. Storage	-20°C	120HR		Appearance without defect	
3	High Temp. & High Humidity Storage	40°C 90%RH	120HR		Appearance without defect	
4	Thermal Shock	-20°C,30min → 25°C,5min → 60°C,30min → 25°C,5min (= 1 cycle)			Appearance without defect	5 cycles



# 13.LCD PRODUCT QUALITY STANDARD

## (1) DISPLAY APPEARANCE

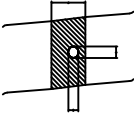
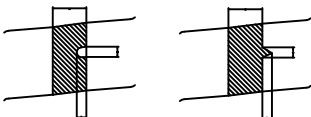
NO	ITEM	C R I T E R I A															
1.	INCLUSIONS (BLACK SPOT , WHITE SPOT , DUST)	(1) ROUND TYPE															
		<table border="1"> <thead> <tr> <th colspan="3">DIAMETER mm (a*)</th> <th>NO. OF DEFECT*</th> </tr> </thead> <tbody> <tr> <td></td> <td>a</td> <td>≦ 0.20</td> <td>NEGLECT</td> </tr> <tr> <td>0.20</td> <td>&lt; a</td> <td>≦ 0.35</td> <td>5 MAX</td> </tr> <tr> <td>0.35</td> <td>&lt; a</td> <td></td> <td>NONE</td> </tr> </tbody> </table>	DIAMETER mm (a*)			NO. OF DEFECT*		a	≦ 0.20	NEGLECT	0.20	< a	≦ 0.35	5 MAX	0.35	< a	
DIAMETER mm (a*)			NO. OF DEFECT*														
	a	≦ 0.20	NEGLECT														
0.20	< a	≦ 0.35	5 MAX														
0.35	< a		NONE														
		(2) LINEAR TYPE															
		<table border="1"> <thead> <tr> <th>LENGTH mm(L)</th> <th>WIDTH mm(W)</th> <th>NO. OF DEFECT</th> </tr> </thead> <tbody> <tr> <td>N A</td> <td>W ≦ 0.03</td> <td>NEGLECT</td> </tr> <tr> <td>L ≦ 3</td> <td>0.03 &lt; W ≦ 0.08</td> <td>6</td> </tr> <tr> <td>3 &lt; L</td> <td>0.08 &lt; W</td> <td>NONE</td> </tr> </tbody> </table>	LENGTH mm(L)	WIDTH mm(W)	NO. OF DEFECT	N A	W ≦ 0.03	NEGLECT	L ≦ 3	0.03 < W ≦ 0.08	6	3 < L	0.08 < W	NONE			
LENGTH mm(L)	WIDTH mm(W)	NO. OF DEFECT															
N A	W ≦ 0.03	NEGLECT															
L ≦ 3	0.03 < W ≦ 0.08	6															
3 < L	0.08 < W	NONE															
2.	SCRATCH	1.SCRATCH ON PROTECTIVE FILM IS PERMITTED . 2.SCRATCH ON POLARIZER SHALL BE AS FOLLOW: (1) ROUND TYPE															
		<table border="1"> <thead> <tr> <th colspan="3">DIAMETER mm (a*)</th> <th>NO. OF DEFECT*</th> </tr> </thead> <tbody> <tr> <td></td> <td>a</td> <td>≦ 0.15</td> <td>NEGLECT</td> </tr> <tr> <td>0.15</td> <td>&lt; a</td> <td>≦ 0.20</td> <td>2 MAX</td> </tr> <tr> <td>0.20</td> <td>&lt; a</td> <td></td> <td>NONE</td> </tr> </tbody> </table>	DIAMETER mm (a*)			NO. OF DEFECT*		a	≦ 0.15	NEGLECT	0.15	< a	≦ 0.20	2 MAX	0.20	< a	
DIAMETER mm (a*)			NO. OF DEFECT*														
	a	≦ 0.15	NEGLECT														
0.15	< a	≦ 0.20	2 MAX														
0.20	< a		NONE														
		(2) LINEAR TYPE BE JUDGED BY 1.-(2) LINEAR TYPE															
3.	DENT	DIAMETER < 1.5mm															
4.	BUBBLE	NOT EXCEEDING 0.5mm AVERAGE DIAMETER IS ACCEPTABLE BETWEEN GLASS AND POLARIZING FILM.															
5.	PIN HOLE	(a+b)/2 ≦ 0.15 mm MAXIMUM NUMBER:IGNORED 0.15 < (a+b)/2 ≦ 0.20 MAXIMUM NUMBER:10															
6.	DOT DEFECT	(a+b)/2 ≦ 0.20 mm MAXIMUM NUMBER:IGNORED 0.20 < (a+b)/2 ≦ 0.30 MAXIMUM NUMBER:5 x = WIDTH															
7.	CONTRAST IRREGULARITY (SPOT)	DIAMETER SPEC. a ≦ 0.50 mm 0.50 < a ≦ 0.75 0.75 < a ≦ 1.00 1.00 < a	NO. OF DEFECT* NEGLECT 5 3 NONE														
8.	DOT WIDTH	DESIGN WIDTH±15%															
9.	COLOR TONE AND UNIFORMITY	OBVIOUS UNEVEN COLOR IS NOT PERMITTED															

(2) NOTE:

• SAFETY

- 1.If the LCD panel breaks, be careful not to allow the liquid crystal to touch your skin.
- 2.If the liquid crystal touches your skin or clothes, please wash it off immediately by using soap and water.

• HANDLING

- 1.Prevent all contact with static electricity, which can damage the CMOS ICs. The module is packaged in a static-shielding bag to prevent damage during shipment, warehousing and removal from the shipping carton.
- 2.Do not remove the panel or frame from the module.
- 3.The polarizing plate on the front surface of the display is very fragile and easily scratched. The module is shipped with a protective liner which must be removed from the polarizing plate prior to assembly.
- 4.Do not wipe the polarizing plate with a dry cloth, as it may easily scratch the surface of polarizing plate.
- 5.Do not use ketonics solvent or aromatic solvent on the polarizing plate. Use a soft cloth soaked with plastic-lens cleaning solution.

• STORAGE

- 1.Store the panel or module in a dark place where the temperature is  $25^{\circ}\text{C}\pm 5^{\circ}\text{C}$  and the humidity is below 65% RH.
- 2.Do not place the module near organics solvents or corrosive gases.
- 3.Do not crush, shake, or jolt the module.

• TERMS OF WARRANTY

- 1.Acceptance inspection period  
The inspection period is within one month after the arrival of the contracted goods at the buyer's factory site.
- 2.Applicable warranty period  
The warranty period is within twelve months from the date of invoice under normal usage and storage conditions.

• TYPICAL OPERATING LIFETIME OF BACKLIGHT

- LED : 50,000HR  
EL : 5,000HR  
CCFT : 10,000HR

REV/DATE	RO/ 03.24.98'					APP	CHK	BY
----------	------------------	--	--	--	--	-----	-----	----

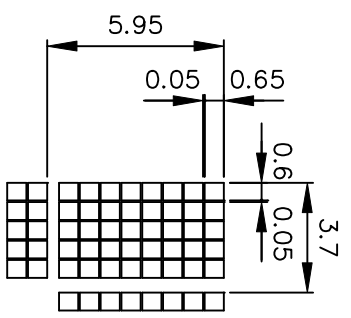
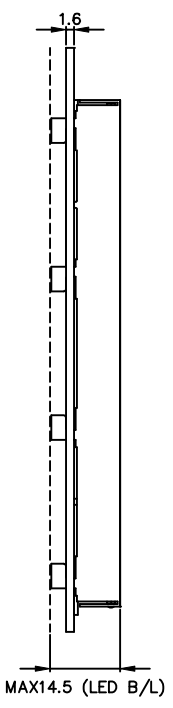
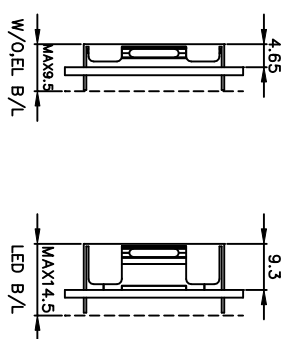
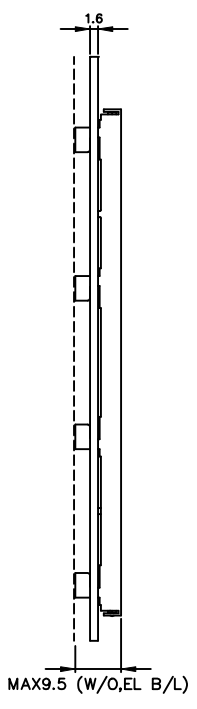
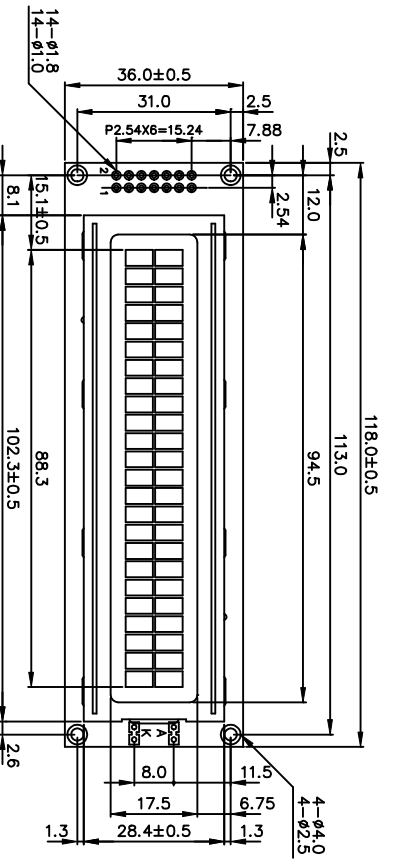

PinNo.	Symbol	Level	Function
1	VSS	-	0V
2	VDD	-	+5V
3	VO	-	Power supply
4	RS	H/L	H:INSTRUCTION CODE INPUT L:DATA INPUT
5	R/W	H/L	H:DATA READ (FROM ICM TO MPU) L:DATA WRITE (FROM MPU TO ICM)
6	E	H,H->L	ENABLE SIGNAL
7	DB0	H/L	DATA BUS LINE
8	DB1	H/L	
9	DB2	H/L	
10	DB3	H/L	
11	DB4	H/L	
12	DB5	H/L	
13	DB6	H/L	
14	DB7	H/L	

Note :

- Resolution : 24 Characters x 2 Lines
- Character Format : 5 x 8 Dots
- Controller : KS0066 (Compatible)
- DC/DC Converter : Without
- General Tolerance : ±0.5 mm

產品編號	LM_B3_025_2	南亞塑膠工業股份有限公司
APPROVE		NAN YA PLASTICS CORPORATION
CHECK		
DESIGN		
DRAW	Moy Ping	87.03.24
TITLE		製品圖
DWG-NO	Mx-x025x2	Rev.A
UNIT		mm
SCALE		