

NAN YA PLASTICS CORP.
ELEC. MATERIALS DIV.
LCD DEPARTMENT

SPECIFICATION

SPEC. NO. : LM021-1
DATE : NOV.07.1997
SHEET NO. : 1/19

U.S. MARKETING ARM:

MARK PRODUCTS CORPORATION
800 N. EDGEWOOD AVENUE
WOOD DALE, IL 60191
TEL: 630-787-9089
FAX: 630-787-9015

SPECIFICATION OF
16x2 LCD MODULE
PRODUCT NO.: LM_82_021_2E

SPEC. NO.: LM021-1

APPROVED BY

EDITED ON : NOV.07.1997

SALES MANAGER	DESIGN MANAGER	PERSON IN CHARGE

REV/DATE

R0/
11.07.97'

APP

CHK

BY

1. MECHANICAL DATA

- (1) Product No. LM_82_021_2E
- (2) Module Size 88.4 (W)mm x 29.0 (H)mm x MAX14.5 (D)mm (LED B.L.)
88.4 (W)mm x 29.0 (H)mm x MAX9.5 (D)mm (W/O, EL B.L.)
- (3) Dot Size 0.50 (W)mm x 0.55 (H)mm
- (4) Dot Pitch 0.57 (W)mm x 0.62 (H)mm
- (5) Number of Characters 16 (W) x 2 (H)Characters
- (6) Character Format 5 (W) x 8 (H)Dots
- (7) Duty 1/16
- (8) LCD Display Mode STN: Gray Mode Yellow Mode Blue Mode
FSTN: Black and White(Normal White/Positive Image)
 Black and White(Normal Black/Negative Image)
- Rear Polarizer: Reflective Transflective Transmissive
- (9) Viewing Direction 6 O'clock 12 O'clock ___O'clock
- (10) Backlight W/O B/L: 26.5 g
- (11) Weight EL B/L: 28 g
LED B/L: 40.5 g

Note :

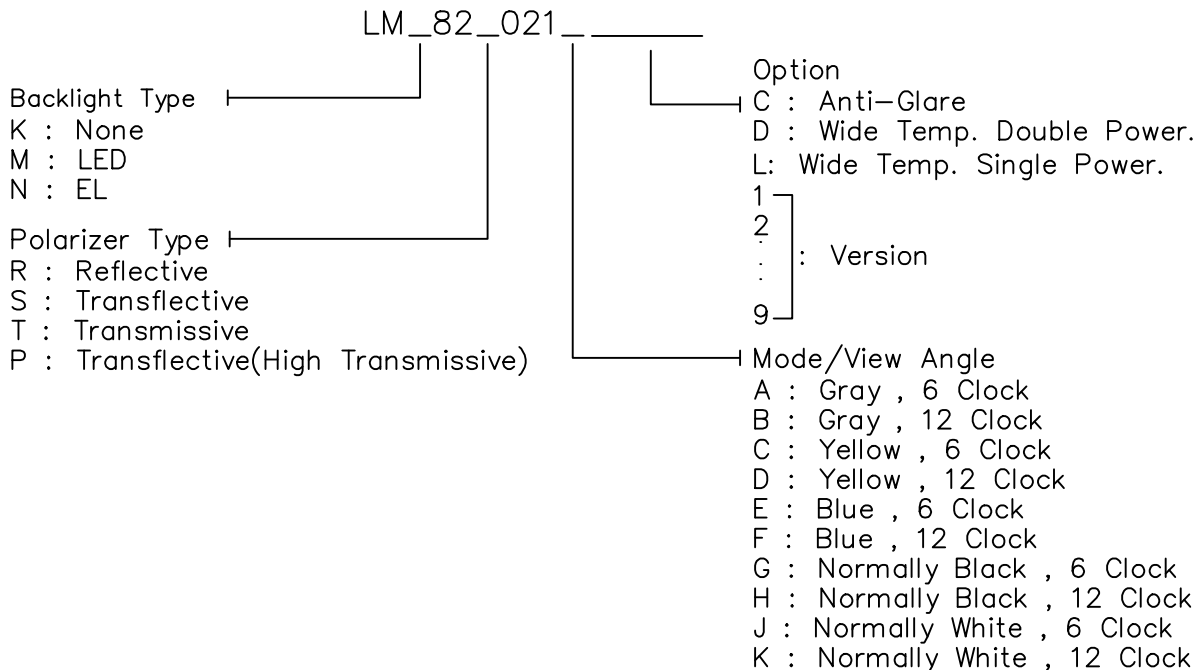

REV/DATE	R0/ 11.07.97'					APP	CHK	BY
----------	------------------	--	--	--	--	-----	-----	----

2. ABSOLUTE MAXIMUM RATINGS

(1) ELECTRICAL ABSOLUTE RATINGS

V_{SS}=0V

ITEM	SYMBOL	MIN	MAX	UNIT	COMMENT
Power Supply for Logic	VDD-VSS	-0.3	6.5	V	
Input Voltage	V _I	-0.3	VDD	V	
Static Electricity	-	-	-	-	Note 1

Note 1 LCM should be grounded during handling LCM.

(2) ENVIRONMENTAL ABSOLUTE MAXIMUM RATINGS

ITEM	NORMAL TEMP.				WIDE TEMP.			
	OPERATING		STORAGE		OPERATING		STORAGE	
	MIN.	MAX.	MIN.	MAX.	MIN.	MAX.	MIN.	MAX.
Ambient Temperature	0	50	-20	70	-20	70	-30	80
Humidity (Without Condensation)	Note 1,3		Note 2,3		Note 3,4		Note 3,5	

Note 1 Ta ≤ 50°C : 85%RH max
Ta > 50°C : Absolute humidity must be lower
than the humidity of 85%RH at 50°C

Note 2 Ta at -20°C will be < 48hrs, at 70°C will be < 120hrs

Note 3 Background color changes slightly depending on ambient temperature.
This phenomenon is reversible.

Note 4 Ta ≤ 70°C : 75%RH max
Ta > 70°C : Absolute humidity must be lower
than the humidity of 75%RH at 70°C

Note 5 Ta at -30°C will be < 48hrs, at 80°C will be < 120hrs

3. ELECTRICAL CHARACTERISTICS

(VDD = 5V±10%)

ITEM	SYMBOL	CONDITION	MIN.	TYP.	MAX.	UNIT
Input Voltage	VIH	H level	0.8VDD	—	VDD	V
	VIO	L level	0	—	0.2VDD	V
Recommended LC Driving Voltage (NORMALLY TEMP. LCM)	VDD-V0	0°C	—	4.8	5.4	V
		25°C	4.2	4.7	5.2	
		50°C	3.8	4.3	—	
Recommended LC Driving Voltage (WIDE TEMP. LCM)	VDD-V0	-20°C	5.9	6.4	7.2	V
		0°C	5.7	6.4	7.2	
		25°C	5.7	6.2	6.8	
		50°C	5.5	5.9	6.5	
		70°C	5.3	5.5	6.1	
Power Supply Current	IDD	VDD = 5.0V	—	—	2.8	mA
LED Power Supply Current	ILED	V _{BL} = 5V _{DC} (R _{BL} = 5Ω)	—	170	—	mA
EL Power Supply Current	IEL	V _{EL} = 110V _{AC} 400Hz	—	—	5.0	mA

4.OPTICAL CHARACTERISTICS

(FOR NORMAL TEMPERATURE MODE LCM)

AT V_{OP}

MODE	ITEM	Cr(Contrast Ratio)		θ (Viewing Angle)		ϕ (Viewing Angle)	
		25℃		25℃		25℃	
		MIN.	TYP.	MIN.	TYP.	MIN.	TYP.
R	A	3.0	4.0	40	65	25	35
	C	5.0	8.0	50	70	28	38
	J						
S	A	3.0	4.0	35	60	20	32
	C	4.0	7.0	45	65	25	35
	J						
T	E/F	2.5	3.0	30	50	20	30
	C/D	2.5	5.0	30	50	20	30
NOTE		NOTE6		NOTE5			

AT $\phi=0^\circ$ $\theta=0^\circ$

ITEM	SYMBOL	CONDITION	MIN.	TYP.	MAX.	UNIT	NOTE
Response Time (rise)	Tr	0℃	-	460	900	ms	NOTE 2
		25℃	-	110	220		
		50℃	-	65	130		
Response Time (fall)	Tf	0℃	-	420	800	ms	NOTE 2
		25℃	-	140	250		
		50℃	-	90	155		

NOTE :

R: REFLECTIVE
S: TRANSFLECTIVE
T: TRANSMISSIVE
A/B: GRAY
C/D: YELLOW
E/F: BLUE
G/H: NORMALLY BLACK
J/K: NORMALLY WHITE

4-1. OPTICAL CHARACTERISTICS

(FOR WIDE TEMPERATURE and DOUBLE POWER MODE LCM)

AT Vop

MODE	ITEM	Cr(Contrast Ratio)		θ (Viewing Angle)		ϕ (Viewing Angle)	
		25℃		25℃		25℃	
		MIN.	TYP.	MIN.	TYP.	MIN.	TYP.
R	A	4	5.5	45	-	30	-
	C	4	10	50	-	30	-
	J						
S	A	3.5	5	45	66	30	37
	C	4	10	50	-	30	40
	J						
T	E	2.5	3.2	45	60	30	40
	G						
NOTE		NOTE6		NOTE5			

AT $\phi=0^\circ$ $\theta=0^\circ$

ITEM	SYMBOL	CONDITION	MIN.	TYP.	MAX.	UNIT	NOTE
Response Time (rise)	Tr	-20℃	-	1600	3200	ms	NOTE 2
		0℃	-	300	600		
		25℃	-	120	240		
		50℃	-	70	140		
		70℃	-	65	130		
Response Time (fall)	Tf	-20℃	-	1500	3000	ms	NOTE 2
		0℃	-	300	600		
		25℃	-	90	180		
		50℃	-	65	130		
		70℃	-	50	100		

NOTE :

R: REFLECTIVE
S: TRANSFLECTIVE
T: TRANSMISSIVE
A/B: GRAY

C/D: YELLOW
E/F: BLUE
G/H: NORMALLY BLACK
J/K: NORMALLY WHITE

(NOTE 1)

Definition of Operation Voltage(Vop)

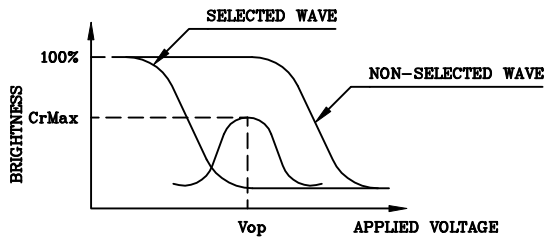

(positive type)

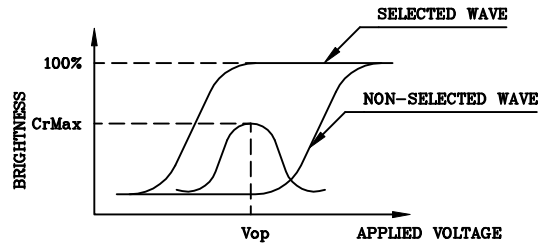

(negative type)

*Conditions

Viewing Angle : 0
 Frame Frequency : 70Hz
 Applied Waveform : 1/N duty, 1/a bias

(NOTE 2)

Definition of Response Time(Tr,Tf)

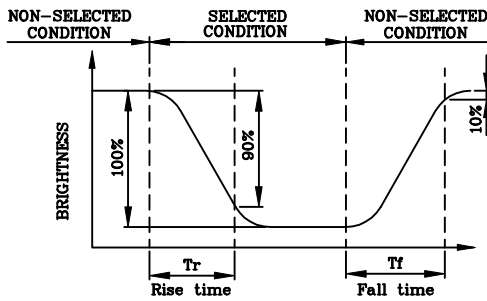

(positive type)

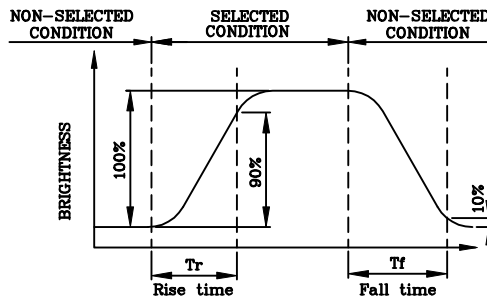

(negative type)

*Conditions

Operating Voltage : Vop
 Viewing Angle (θ, ϕ) : (0,0)
 Frame Frequency : 70Hz
 Applied Waveform : 1/N duty, 1/a bias

(NOTE 3)

Description of Measuring Equipment and Driving Waveforms

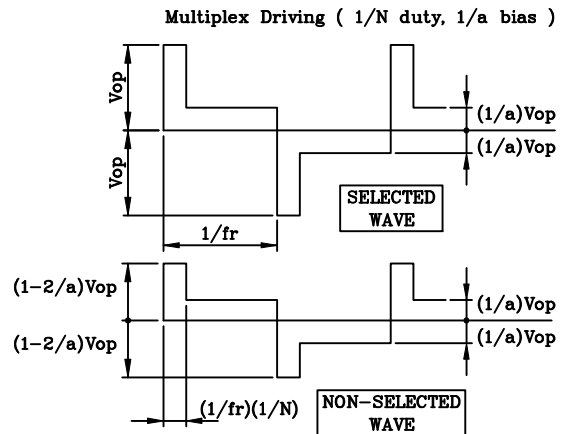
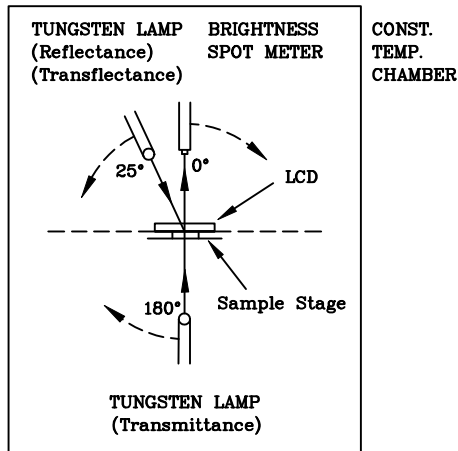

(NOTE 4)

Definition of Viewing Direction

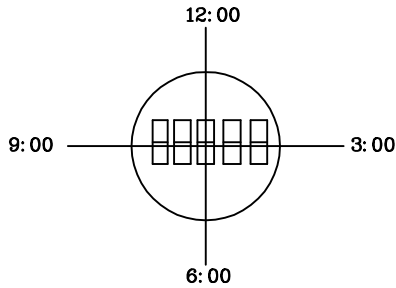

(NOTE 5)

Definition of Viewing Angle

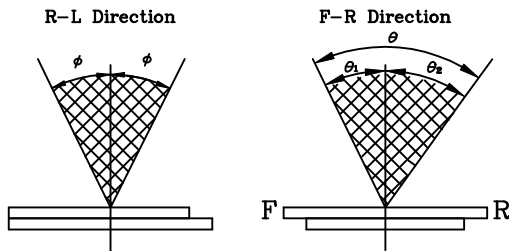

$$\theta = \theta_1 + \theta_2$$

*Conditions

Operating Voltage : V_{op}
 Frame Frequency : 70Hz
 Applied Waveform : 1/N duty, 1/a bias
 Contrast Ratio : larger than 2

(NOTE 6)

Definition of Contrast Ratio (Cr)

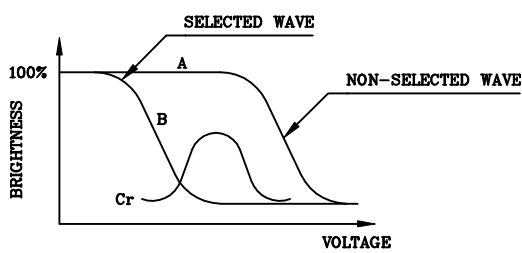

(positive type)

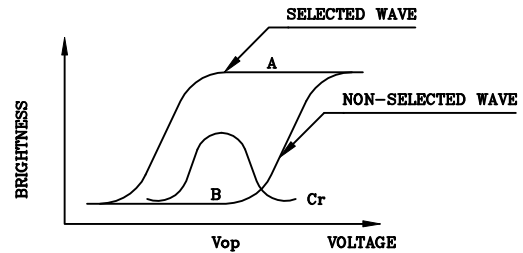

(negative type)

Contrast Ratio : $Cr = A/B$

*Conditions

Viewing Angle : 0
 Frame Frequency : 70Hz
 Applied Waveform : 1/N duty, 1/a bias

REV/DATE	R0/ 11.07.97'					APP	CHK	BY
----------	------------------	--	--	--	--	-----	-----	----

5. BLOCK DIAGRAM

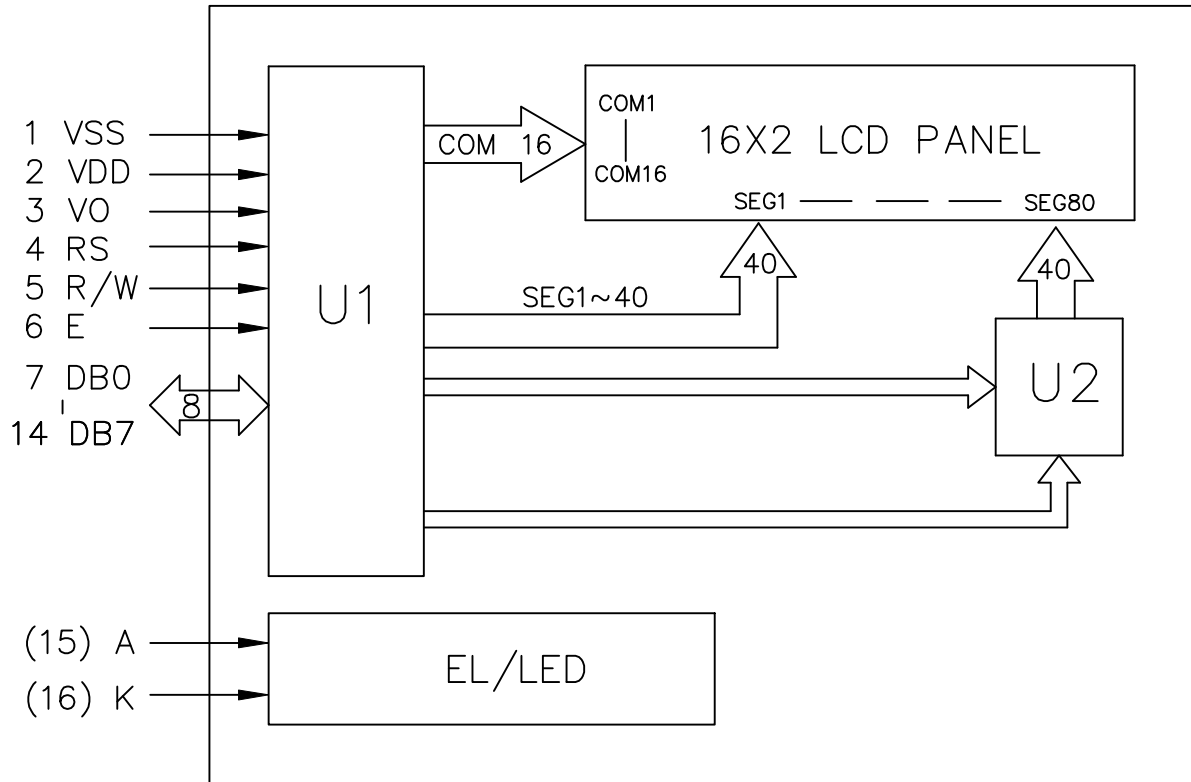

6. INTERNAL PIN CONNECTION

PinNo.	Symbol	Level	Function
1	V _{SS}	—	0V
2	V _{DD}	—	+5V
3	V _O	—	—
4	RS	H/L	L: INSTRUCTION CODE INPUT H: DATA INPUT
5	R/W	H/L	H: DATA READ (FROM LCM TO MPU) L: DATA WRITE (FROM MPU TO LCM)
6	E	H, H->L	ENABLE SIGNAL
7	DB0	H/L	DATA BUS LINE
8	DB1	H/L	
9	DB2	H/L	
10	DB3	H/L	
11	DB4	H/L	
12	DB5	H/L	
13	DB6	H/L	
14	DB7	H/L	
(15)	A	—	Power Supply For LED/EL
(16)	K	—	

7. POWER SUPPLY

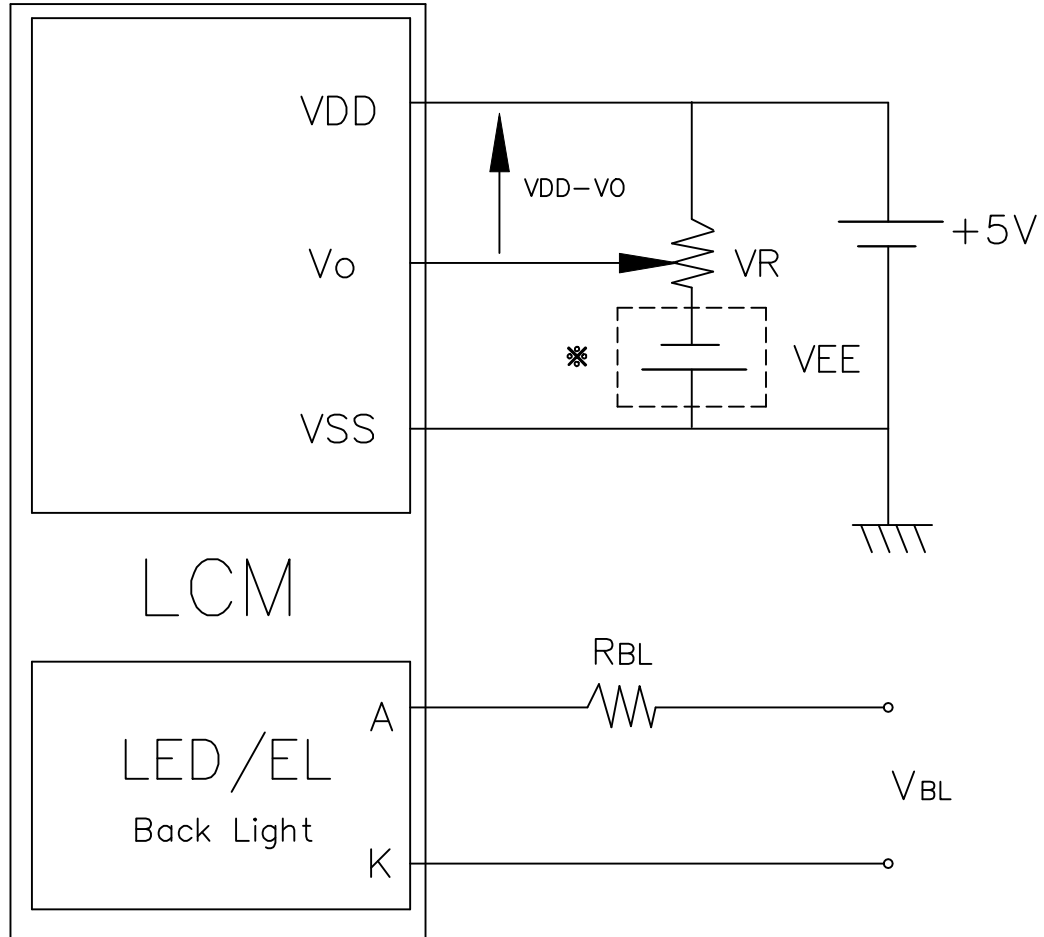

Recommended Value for RBL and VBL

ITEM Back Light	RBL		VBL	
	LED	EL	LED	EL
Interface				
14 PIN	5Ω	0Ω	5V	110V _{DC} 400Hz
16 PIN	0Ω			

8. TIMING CHARACTERISTICS

Item	Symbol	Test Condition	Min.	Typ.	Max.	Unit
Enable cycle time	t_{cyc}	Fig. a, Fig. b	500	-	-	ns
Enable pulse width	PW_{EH}	Fig. a, Fig. b	230	-	-	ns
Enable rise/fall time	t_{Er}, t_{Ef}	Fig. a, Fig. b	-	-	20	ns
RS, R/W set up time	t_{AS}	Fig. a, Fig. b	40	-	-	ns
RS, R/W hold time	t_{H1}	Fig. a, Fig. b	10	-	-	ns
Data set up time	t_{DSW}	Fig. a	60	-	-	ns
Data output delay time	t_{DDR}	Fig. b	-	-	120	ns
Data write hold time	t_{H2}	Fig. a	10	-	-	ns
Data read hold time	t_{H2}	Fig. b	5	-	-	ns

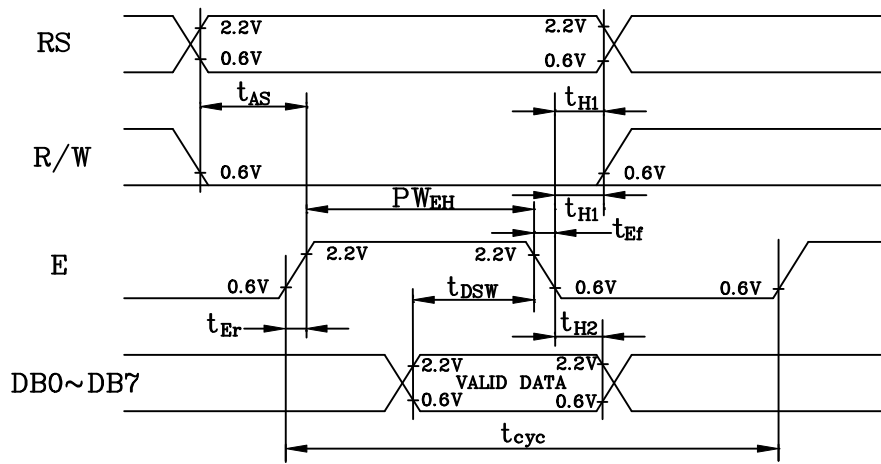

Fig.a Interface timing (data write)

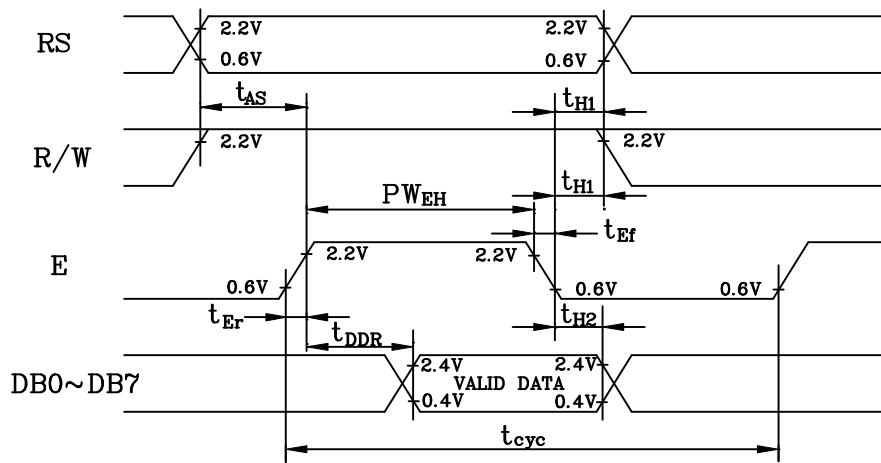

Fig.b Interface timing (data read)

9. CONTROL and DISPLAY COMMAND

COMMAND	RS	R/W	DB7	DB6	DB5	DB4	DB3	DB2	DB1	DB0	EXCUTION TIME (FOSC=250kHz)	REMARK																		
DISPLAY CLEAR	L	L	L	L	L	L	L	L	L	H	1.64ms																			
RETURN HOME	L	L	L	L	L	L	L	L	H	X	1.64ms	CURSOR MOVE TO FIRST DIGIT																		
ENTRY MODE SET	L	L	L	L	L	L	L	H	I/D	SH	40μS	•I/D: SET CURSOR MOVE DIRECTION <table border="1"> <tr><td>I/D</td><td>H</td><td>INCREASE</td></tr> <tr><td>I/D</td><td>L</td><td>DECREASE</td></tr> </table> •SH: SPECIFIES SHIFT OF DISPLAY <table border="1"> <tr><td>SH</td><td>H</td><td>DISPLAY IS SHIFTED</td></tr> <tr><td>SH</td><td>L</td><td>DISPLAY IS NOT SHIFTED</td></tr> </table>	I/D	H	INCREASE	I/D	L	DECREASE	SH	H	DISPLAY IS SHIFTED	SH	L	DISPLAY IS NOT SHIFTED						
I/D	H	INCREASE																												
I/D	L	DECREASE																												
SH	H	DISPLAY IS SHIFTED																												
SH	L	DISPLAY IS NOT SHIFTED																												
DISPLAY ON/OFF	L	L	L	L	L	L	H	D	C	B	40μS	•DISPLAY <table border="1"> <tr><td>D</td><td>H</td><td>DISPLAY ON</td></tr> <tr><td>D</td><td>L</td><td>DISPLAY OFF</td></tr> </table> •CURSOR <table border="1"> <tr><td>C</td><td>H</td><td>CURSOR ON</td></tr> <tr><td>C</td><td>L</td><td>CURSOR OFF</td></tr> </table> •BLINKING <table border="1"> <tr><td>B</td><td>H</td><td>BLINKING ON</td></tr> <tr><td>B</td><td>L</td><td>BLINKING OFF</td></tr> </table>	D	H	DISPLAY ON	D	L	DISPLAY OFF	C	H	CURSOR ON	C	L	CURSOR OFF	B	H	BLINKING ON	B	L	BLINKING OFF
D	H	DISPLAY ON																												
D	L	DISPLAY OFF																												
C	H	CURSOR ON																												
C	L	CURSOR OFF																												
B	H	BLINKING ON																												
B	L	BLINKING OFF																												
SHIFT	L	L	L	L	L	H	S/C	R/L	X	X	40μS	<table border="1"> <tr><td>SC</td><td>H</td><td>DISPLAY SHIFT</td></tr> <tr><td>SC</td><td>L</td><td>CURSOR MOVE</td></tr> </table> <table border="1"> <tr><td>R/L</td><td>H</td><td>RIGHT SHIFT</td></tr> <tr><td>R/L</td><td>L</td><td>LEFT SHIFT</td></tr> </table>	SC	H	DISPLAY SHIFT	SC	L	CURSOR MOVE	R/L	H	RIGHT SHIFT	R/L	L	LEFT SHIFT						
SC	H	DISPLAY SHIFT																												
SC	L	CURSOR MOVE																												
R/L	H	RIGHT SHIFT																												
R/L	L	LEFT SHIFT																												
SET FUNCTION	L	L	L	L	H	DL	N	F	X	X	40μS	<table border="1"> <tr><td>DL</td><td>H</td><td>8 DITS INTERFACE</td></tr> <tr><td>DL</td><td>L</td><td>4 BITS INTERFACE</td></tr> </table> <table border="1"> <tr><td>N</td><td>H</td><td>2 LINE DISPLAY</td></tr> <tr><td>N</td><td>L</td><td>1 LINE DISPLAY</td></tr> </table> <table border="1"> <tr><td>F</td><td>H</td><td>5 X 10 DOTS</td></tr> <tr><td>F</td><td>L</td><td>5 X 7 DOTS</td></tr> </table>	DL	H	8 DITS INTERFACE	DL	L	4 BITS INTERFACE	N	H	2 LINE DISPLAY	N	L	1 LINE DISPLAY	F	H	5 X 10 DOTS	F	L	5 X 7 DOTS
DL	H	8 DITS INTERFACE																												
DL	L	4 BITS INTERFACE																												
N	H	2 LINE DISPLAY																												
N	L	1 LINE DISPLAY																												
F	H	5 X 10 DOTS																												
F	L	5 X 7 DOTS																												
SET CG RAM ADDRESS	L	L	L	H	CG RAM address (corresponds to cursor address)					40μS	CG RAM Data is sent and received after this setting																			
SET DD RAM ADDRESS	L	L	H	DD RAM address					40μS	DD RAM Data is sent and received after this setting																				
READ BUSY FLAG & ADDRESS	L	H	BF	Address Counter used for Both DD & CG RAM address					0μS	<table border="1"> <tr><td>BF</td><td>H</td><td>Busy</td></tr> <tr><td>BF</td><td>L</td><td>Ready</td></tr> </table> -Reads BF indication internal operating is being performed. -reads address counter contents	BF	H	Busy	BF	L	Ready														
BF	H	Busy																												
BF	L	Ready																												
WRITE DATA	H	L	Write Data					46μS	Write data into DD or CG RAM																					
READ DATA	H	H	Read Data					46μS	Read data form DD or CGRAM																					

X : Don't care

REV/DATE	R0/ 11.07.97'									APP	CHK	BY
----------	------------------	--	--	--	--	--	--	--	--	-----	-----	----

10.DISPLAY PATTERN

Display Data RAM Address
Versus Character Position

1	2	3	4	5	6	7	8	9	10	11	12	13	14	15	16
00	01	02	03	04	05	06	07	08	09	0A	0B	0C	0D	0E	0F
40	41	42	43	44	45	46	47	48	49	4A	4B	4C	4D	4E	4F

16 x 2 Display Pattern

11.CHARACTER FONT TABLE

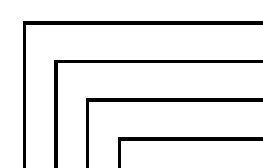
	0	0	0	0	0	0	0	1	1	1	1	1	1
	0	0	0	1	1	1	1	0	0	1	1	1	1
	0	1	1	0	0	1	1	1	1	0	0	1	1
	0	0	1	0	1	0	1	0	1	0	1	0	1
XXXX0000			0	@	P	`	P		-	夕	ミ	α	P
XXXX0001		!	1	A	Q	a	q	。	ア	チ	△	ä	Q
XXXX0010		"	2	B	R	b	r	「	イ	ツ	×	β	θ
XXXX0011		#	3	C	S	c	s	」	ウ	テ	ε	ε	ω
XXXX0100		\$	4	D	T	d	t	、	エ	ト	†	Ω	Ω
XXXX0101		%	5	E	U	e	u	・	オ	ナ	1	ü	Ü
XXXX0110		&	6	F	V	f	v	ヲ	カ	ニ	ヨ	ρ	Σ
XXXX0111		'	7	G	W	g	w	ア	キ	ヌ	ラ	Q	π
XXXX1000		(8	H	X	h	x	イ	ク	ネ	リ	√	×
XXXX1001)	9	I	Y	i	y	ウ	ケ	ル	”	U	U
XXXX1010		*	:	J	Z	j	z	エ	コ	ハ	レ	i	≠
XXXX1011		+	;	K	[k	[オ	サ	ヒ	ロ	*	≠
XXXX1100		,	<	L	¥	l	l	カ	シ	フ	ワ	φ	≠
XXXX1101		-	=	M]	m]	ユ	ズ	ハ	ン	も	÷
XXXX1110		.	>	N	^	n	^	ヨ	セ	ホ	”	ñ	
XXXX1111		/	?	O	_	o	_	ツ	リ	マ	”	ö	■

12. RELIABILITY TEST

NO	ITEM	CONDITION			STANDARD	NOTE
1	High Temp. Storage	70°C	120HR		Appearance without defect	
2	Low Temp. Storage	-20°C	120HR		Appearance without defect	
3	High Temp. & High Humidity Storage	40°C 90%RH	120HR		Appearance without defect	
4	Thermal Shock	-20°C,30min → 25°C,5min → 60°C,30min → 25°C,5min (= 1 cycle)			Appearance without defect	5 cycles

13.LCD PRODUCT QUALITY STANDARD

(1) DISPLAY APPEARANCE

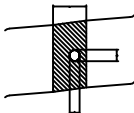
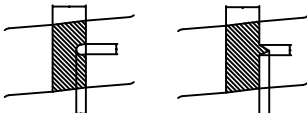
NO	ITEM	C R I T E R I A													
1.	INCLUSIONS (BLACK SPOT , WHITE SPOT , DUST)	(1) ROUND TYPE													
		<table border="1"> <thead> <tr> <th>DIAMETER mm (a*)</th> <th>NO. OF DEFECT*</th> </tr> </thead> <tbody> <tr> <td>$a \leq 0.20$</td> <td>NEGLECT</td> </tr> <tr> <td>$0.20 < a \leq 0.35$</td> <td>5 MAX</td> </tr> <tr> <td>$0.35 < a$</td> <td>NONE</td> </tr> </tbody> </table>	DIAMETER mm (a*)	NO. OF DEFECT*	$a \leq 0.20$	NEGLECT	$0.20 < a \leq 0.35$	5 MAX	$0.35 < a$	NONE					
DIAMETER mm (a*)	NO. OF DEFECT*														
$a \leq 0.20$	NEGLECT														
$0.20 < a \leq 0.35$	5 MAX														
$0.35 < a$	NONE														
		(2) LINEAR TYPE													
		<table border="1"> <thead> <tr> <th>LENGTH mm(L)</th> <th>WIDTH mm(W)</th> <th>NO. OF DEFECT</th> </tr> </thead> <tbody> <tr> <td>N A</td> <td>$W \leq 0.03$</td> <td>NEGLECT</td> </tr> <tr> <td>$L \leq 3$</td> <td>$0.03 < W \leq 0.08$</td> <td>6</td> </tr> <tr> <td>$3 < L$</td> <td>$0.08 < W$</td> <td>NONE</td> </tr> </tbody> </table>	LENGTH mm(L)	WIDTH mm(W)	NO. OF DEFECT	N A	$W \leq 0.03$	NEGLECT	$L \leq 3$	$0.03 < W \leq 0.08$	6	$3 < L$	$0.08 < W$	NONE	
LENGTH mm(L)	WIDTH mm(W)	NO. OF DEFECT													
N A	$W \leq 0.03$	NEGLECT													
$L \leq 3$	$0.03 < W \leq 0.08$	6													
$3 < L$	$0.08 < W$	NONE													
2.	SCRATCH	1.SCRATCH ON PROTECTIVE FILM IS PERMITTED . 2.SCRATCH ON POLARIZER SHALL BE AS FOLLOW: (1) ROUND TYPE													
		<table border="1"> <thead> <tr> <th>DIAMETER mm (a*)</th> <th>NO. OF DEFECT*</th> </tr> </thead> <tbody> <tr> <td>$a \leq 0.15$</td> <td>NEGLECT</td> </tr> <tr> <td>$0.15 < a \leq 0.20$</td> <td>2 MAX</td> </tr> <tr> <td>$0.20 < a$</td> <td>NONE</td> </tr> </tbody> </table>	DIAMETER mm (a*)	NO. OF DEFECT*	$a \leq 0.15$	NEGLECT	$0.15 < a \leq 0.20$	2 MAX	$0.20 < a$	NONE					
DIAMETER mm (a*)	NO. OF DEFECT*														
$a \leq 0.15$	NEGLECT														
$0.15 < a \leq 0.20$	2 MAX														
$0.20 < a$	NONE														
		(2) LINEAR TYPE BE JUDGED BY 1.--(2) LINEAR TYPE													
3.	DENT	DIAMETER < 1.5mm													
4.	BUBBLE	NOT EXCEEDING 0.5mm AVERAGE DIAMETER IS ACCEPTABLE BETWEEN GLASS AND POLARIZING FILM.													
5.	PIN HOLE	$(a+b)/2 \leq 0.15$ mm MAXIMUM NUMBER: IGNORED													
		$0.15 < (a+b)/2 \leq 0.20$ MAXIMUM NUMBER: 10													
6.	DOT DEFECT	$(a+b)/2 \leq 0.20$ mm MAXIMUM NUMBER: IGNORED													
		$0.20 < (a+b)/2 \leq 0.30$ MAXIMUM NUMBER: 5 x = WIDTH													
															
															
7.	CONTRAST IRREGULARITY (SPOT)	DIAMETER SPEC.													
		<table border="1"> <thead> <tr> <th>DIAMETER SPEC.</th> <th>NO. OF DEFECT*</th> </tr> </thead> <tbody> <tr> <td>$a \leq 0.50$ mm</td> <td>NEGLECT</td> </tr> <tr> <td>$0.50 < a \leq 0.75$</td> <td>5</td> </tr> <tr> <td>$0.75 < a \leq 1.00$</td> <td>3</td> </tr> <tr> <td>$1.00 < a$</td> <td>NONE</td> </tr> </tbody> </table>	DIAMETER SPEC.	NO. OF DEFECT*	$a \leq 0.50$ mm	NEGLECT	$0.50 < a \leq 0.75$	5	$0.75 < a \leq 1.00$	3	$1.00 < a$	NONE			
DIAMETER SPEC.	NO. OF DEFECT*														
$a \leq 0.50$ mm	NEGLECT														
$0.50 < a \leq 0.75$	5														
$0.75 < a \leq 1.00$	3														
$1.00 < a$	NONE														
8.	DOT WIDTH	DESIGN WIDTH \pm 15%													
9.	COLOR TONE AND UNIFORMITY	OBVIOUS UNEVEN COLOR IS NOT PERMITTED													

(2) NOTE:

• SAFETY

- 1.If the LCD panel breaks, be careful not to allow the liquid crystal to touch your skin.
- 2.If the liquid crystal touches your skin or clothes, please wash it off immediately by using soap and water.

• HANDLING

- 1.Prevent all contact with static electricity, which can damage the CMOS ICs. The module is packaged in a static-shielding bag to prevent damage during shipment, warehousing and removal from the shipping carton.
- 2.Do not remove the panel or frame from the module.
- 3.The polarizing plate on the front surface of the display is very fragile and easily scratched. The module is shipped with a protective liner which must be removed from the polarizing plate prior to assembly.
- 4.Do not wipe the polarizing plate with a dry cloth, as it may easily scratch the surface of polarizing plate.
- 5.Do not use ketonics solvent or aromatic solvent on the polarizing plate. Use a soft cloth soaked with plastic-lens cleaning solution.

• STORAGE

- 1.Store the panel or module in a dark place where the temperature is $25^{\circ}\text{C}\pm 5^{\circ}\text{C}$ and the humidity is below 65% RH.
- 2.Do not place the module near organics solvents or corrosive gases.
- 3.Do not crush, shake, or jolt the module.

• TERMS OF WARRANTY

- 1.Acceptance inspection period
The inspection period is within one month after the arrival of the contracted goods at the buyer's factory site.
- 2.Applicable warranty period
The warranty period is within twelve months from the date of invoice under normal usage and storage conditions.

• TYPICAL OPERATING LIFETIME OF BACKLIGHT

- LED : 50,000HR
EL : 5,000HR
CCFT : 10,000HR

REV/DATE	R0/ 11.07.97'					APP	CHK	BY
----------	------------------	--	--	--	--	-----	-----	----

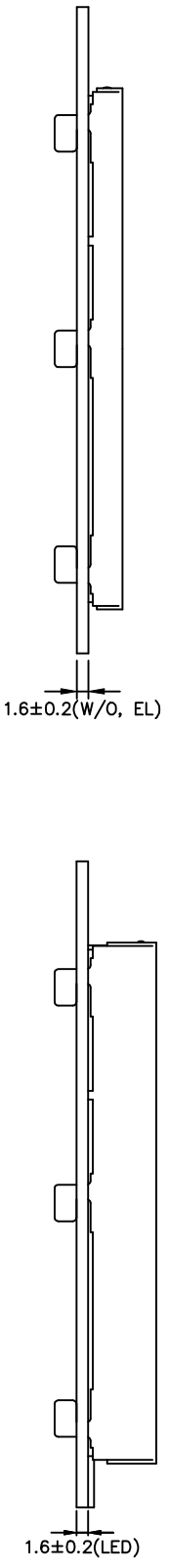
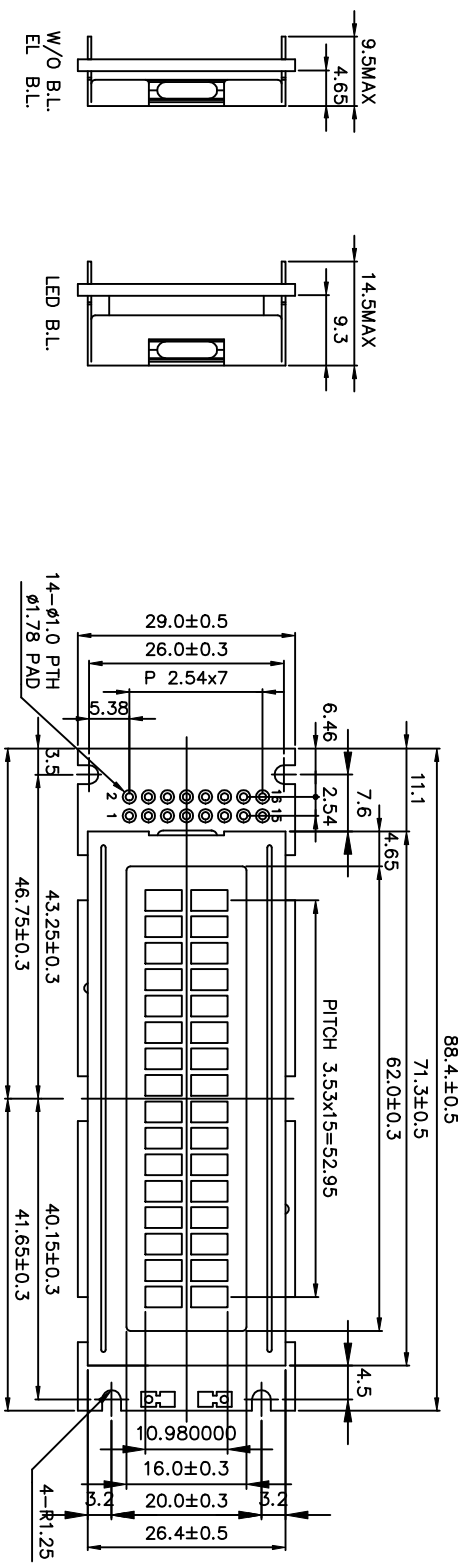

PinNo	Symbol
1	VSS
2	VDD
3	V _O
4	RS
5	R/W
6	E
7	DB0
8	DB1
9	DB2
10	DB3
11	DB4
12	DB5
13	DB6
14	DB7
15	A
16	K

- NOTES :
1. RESOLUTION : 16 X 2.
 2. Character Format : 5 X 8 dots.
 3. General Tolerance : ±0.5mm.

產品編號	LM_82_021_2E	南亞塑膠工業股份有限公司
NAME		NAN YA PLASTICS CORPORATION
DATE		
APPROVE		製 品 圖
CHECK		
DESING		
DRAW	MAY PING 86.11.07	
DWG-NO	MXEX021XA	UNIT : mm
Rev.	A	SCALE :