

NAN YA PLASTICS CORP. ELEC. MATERIALS DIV. LCD DEPARTMENT	SPECIFICATION	SPEC. NO. : LM119-0 DATE : Apr. 10, 1997 SHEET NO. : 1/16
---	---------------	---

U.S. MARKETING ARM:

MARK PRODUCTS CORPORATION
 800 N. EDGEWOOD AVENUE
 WOOD DALE, IL 60191
 TEL: 630-787-9089
 FAX: 630-787-9015

SPECIFICATION OF
 16x2 LCD MODULE
 PRODUCT NO.: LM_83_119_E

SPEC. NO.: LM119-0

APPROVED BY

EDITED ON : Apr. 10, 1997

TECHNICAL MANAGER	DESIGN MANAGER	PERSON IN CHARGE

REV/DATE	RO/ 04.10.97'					APP	CHK	BY
----------	------------------	--	--	--	--	-----	-----	----

1. MECHANICAL DATA

- | | |
|--------------------------|---|
| (1) Product No. | LM_83_119_E |
| (2) Module Size | 85.0 (W)mm x 36.0 (H)mm x MAX9.5 (D)mm
(W/O, EL Backlight)
85.0 (W)mm x 36.0 (H)mm x MAX12.5 (D)mm
(Edge-type LED Backlight) |
| (3) Dot Size | 0.6 (W)mm x 0.6 (H)mm |
| (4) Dot Pitch | 0.65 (W)mm x 0.65 (H)mm |
| (5) Number of Characters | 16 (W) x 2 (H)Characters |
| (6) Character Format | 5 (W) x 7 (H)Dots + Cursor |
| (7) Duty | 1/16 |
| (8) LCD Display Mode | STN: <input type="checkbox"/> Gray Mode <input type="checkbox"/> Yellow Mode <input type="checkbox"/> Blue Mode
FSTN: <input type="checkbox"/> Black and White(Normally White/Positive Image)
<input type="checkbox"/> Black and White(Normally Black/Negative Image)
Rear Polarizer: <input type="checkbox"/> Reflective <input type="checkbox"/> Transflective <input type="checkbox"/> Transmissive |
| (9) Viewing Direction | <input type="checkbox"/> 6 O'clock <input type="checkbox"/> 12 O'clock <input type="checkbox"/> ____O'clock |
| (10) Backlight | <input type="checkbox"/> W/O <input type="checkbox"/> LED <input type="checkbox"/> EL |
| (11) Weight | W/O B/L: about 31 g
EL B/L: about 33 g
LED B/L: about 37 g (Edge-type) |

Note :

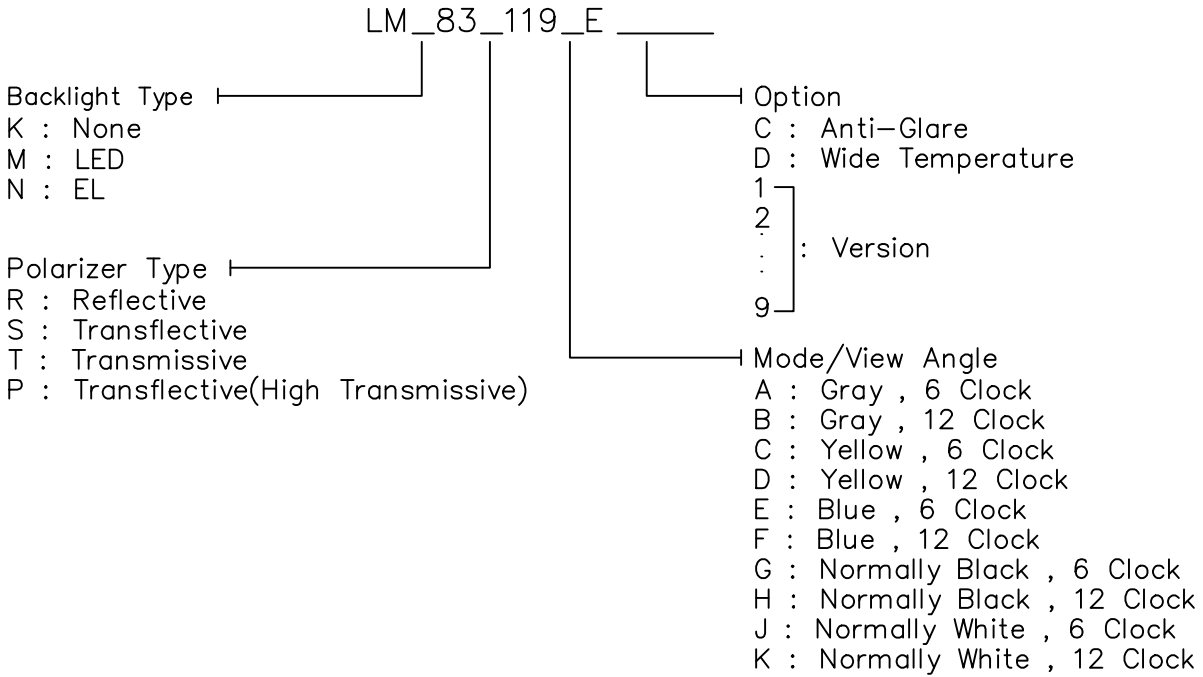

2. ABSOLUTE MAXIMUM RATINGS

(1) ELECTRICAL ABSOLUTE RATINGS

VSS=0V

	SYMBOL	MIN	MAX	UNIT	COMMENT
Power Supply for Logic	VDD-VSS	-0.3	6.5	V	
Power Supply for LCD	VDD-VL	-0.3	13.5	V	
Input Voltage	VI	-0.3	VDD	V	
Static Electricity	-	-	-	-	Note 1

Note 1 LCM should be grounded during handling LCM.

(2) ENVIRONMENTAL ABSOLUTE MAXIMUM RATINGS

ITEM	NORMAL TEMP.				WIDE TEMP.			
	OPERATING		STORAGE		OPERATING		STORAGE	
	MIN.	MAX.	MIN.	MAX.	MIN.	MAX.	MIN.	MAX.
Ambient Temperature	0	50	-20	70	-20	70	-30	80
Humidity (Without Condensation)	Note 1,3		Note 2,3		Note 3,4		Note 3,5	

Note 1 $T_a \leq 50^\circ\text{C}$: 85%RH max
 $T_a > 50^\circ\text{C}$: Absolute humidity must be lower than the humidity of 85%RH at 50°C

Note 2 T_a at -20°C will be < 48hrs, at 70°C will be < 120hrs

Note 3 Background color changes slightly depending on ambient temperature. This phenomenon is reversible.

Note 4 $T_a \leq 70^\circ\text{C}$: 75%RH max
 $T_a > 70^\circ\text{C}$: Absolute humidity must be lower than the humidity of 75%RH at 70°C

Note 5 T_a at -30°C will be < 48hrs, at 80°C will be < 120hrs

3. ELECTRICAL CHARACTERISTICS

(VDD=5V±10%)

ITEM	SYMBOL	CONDITION	MIN.	TYP.	MAX.	UNIT
Input Voltage	VIH	H level	0.8VDD	—	VDD	V
	VIO	L level	0	—	0.2VDD	V
Recommended LC Driving Voltage (NORMAL TEMP. LCM)	VDD-VL	0°C	—	4.8	5.4	V
		25°C	4.2	4.6	5.1	
		50°C	3.9	4.3	—	
Recommended LC Driving Voltage (WIDE TEMP. LCM)	VDD-VL	-20°C	—	6.4	7.2	V
		0°C	—	6.4	—	
		25°C	—	6.1	—	
		50°C	—	5.9	—	
		70°C	5.2	5.5	—	
Power Supply Current	IDD	VDD-VL=4.6V	—	1.0	—	mA
LED Power Supply Current	ILED	VBL = 5Vdc	—	120	—	mA
EL Power Supply Current	IEL	VBL = 110Vac 400Hz	—	—	5.0	mA

4.OPTICAL CHARACTERISTICS

(FOR NORMAL TEMPERATURE MODE LCM)

AT Vop

MODE	ITEM	Cr(Contrast Ratio)		θ (Viewing Angle)		ϕ (Viewing Angle)	
		25°C		25°C		25°C	
		MIN.	TYP.	MIN.	TYP.	MIN.	TYP.
R	A	—	5	40	—	30	—
	C	5	10	40	—	30	—
	J	—	—	—	—	—	—
S	A	3	4.2	40	—	20	—
	C	4	8	40	—	30	—
	J	—	—	—	—	—	—
T	C	4	8	40	—	30	—
	E	2.5	3.2	35	—	25	—
NOTE		NOTE6		NOTE5			

AT $\phi=0^\circ$ $\theta=0^\circ$

ITEM	SYMBOL	CONDITION	MIN.	TYP.	MAX.	UNIT	NOTE
Response Time (rise)	Tr	0°C	—	460	900	ms	NOTE 2
		25°C	—	100	250		
		50°C	—	65	—		
Response Time (fall)	Tf	0°C	—	420	800	ms	NOTE 2
		25°C	—	150	300		
		50°C	—	90	—		

NOTE :

R: REFLECTIVE
S: TRANSFLECTIVE
T: TRANSMISSIVE
A: GRAY
C: YELLOW
E: BLUE
G: NORMALLY BLACK
J: NORMALLY WHITE

4-1. OPTICAL CHARACTERISTICS

(FOR WIDE TEMPERATURE MODE LCM)

AT Vop

MODE	ITEM	Cr(Contrast Ratio)		θ (Viewing Angle)		ϕ (Viewing Angle)	
		25℃		25℃		25℃	
		MIN.	TYP.	MIN.	TYP.	MIN.	TYP.
R	A	-	4.5	50	70	25	30
	C	4	10	50	75	30	40
	J	-	-	-	-	-	-
S	A	-	3.7	40	60	25	34
	C	4.5	10	50	75	30	40
	J	-	-	-	-	-	-
T	C	-	-	-	-	-	-
	E	2.5	3.2	40	60	20	30
NOTE		NOTE6		NOTE5			

AT $\phi=0^\circ$ $\theta=0^\circ$

ITEM	SYMBOL	CONDITION	MIN.	TYP.	MAX.	UNIT	NOTE
Response Time (rise)	Tr	-20℃	-	1530	3000	ms	NOTE 2
		0℃	-	270	540		
		25℃	-	130	260		
		50℃	-	70	140		
		70℃	-	65	130		
Response Time (fall)	Tr	-20℃	-	1490	3000	ms	NOTE 2
		0℃	-	310	600		
		25℃	-	90	180		
		50℃	-	48	100		
		70℃	-	40	80		

NOTE :

R: REFLECTIVE
S: TRANSFLECTIVE
T: TRANSMISSIVE
A: GRAY

C: YELLOW
E: BLUE
G: NORMALLY BLACK
J: NORMALLY WHITE

(NOTE 1)

Definition of Operation Voltage(Vop)

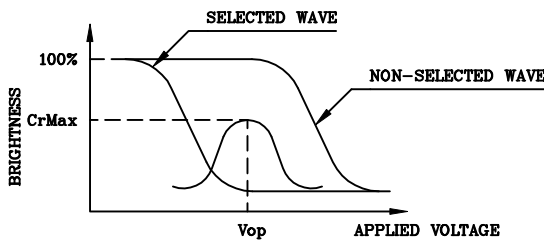

(positive type)

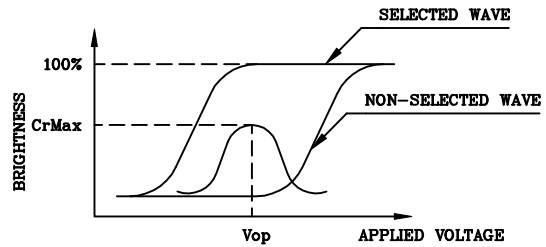

(negative type)

*Conditions

Viewing Angle : 0
Frame Frequency : 70Hz
Applied Waveform : 1/N duty, 1/a bias

(NOTE 2)

Definition of Response Time(Tr,Tf)

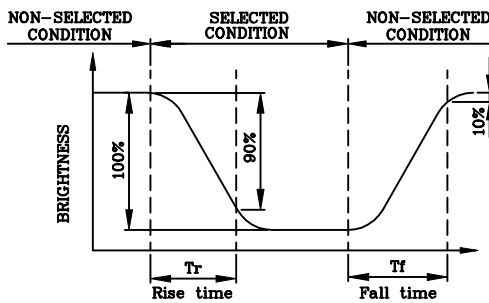

(positive type)

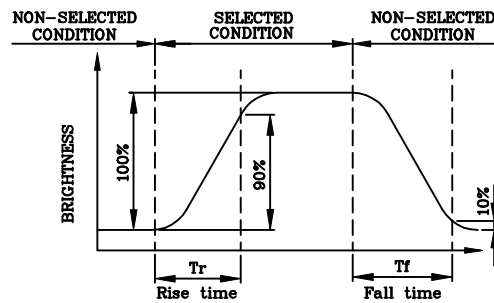

(negative type)

*Conditions

Operating Voltage : Vop
Viewing Angle (θ,θ) : (0,0)
Frame Frequency : 70Hz
Applied Waveform : 1/N duty, 1/a bias

(NOTE 3)

Description of Measuring Equipment and Driving Waveforms

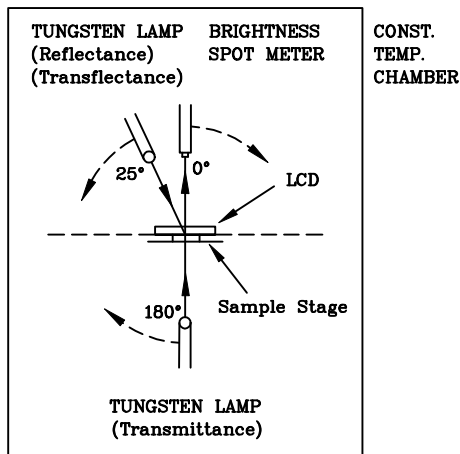

Multiplex Driving (1/N duty, 1/a bias)

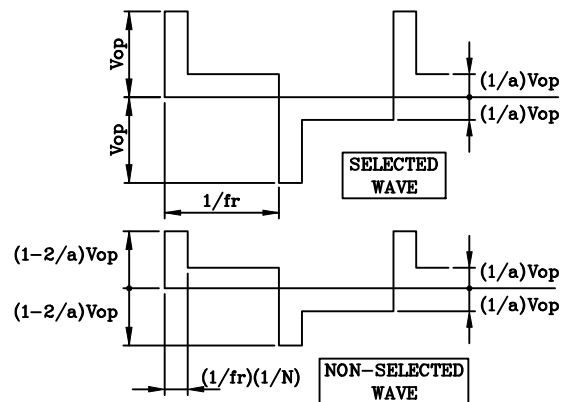

(NOTE 4)

Definition of Viewing Direction

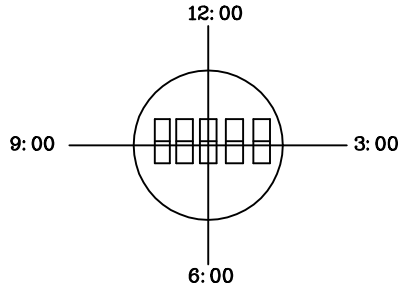

(NOTE 5)

Definition of Viewing Angle

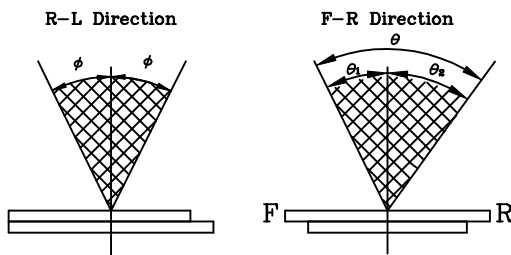

$$\theta = \theta_1 + \theta_2$$

*Conditions

Operating Voltage : Vop
 Frame Frequency : 70Hz
 Applied Waveform : 1/N duty, 1/a bias
 Contrast Ratio : larger than 2

(NOTE 6)

Definition of Contrast Ratio (Cr)

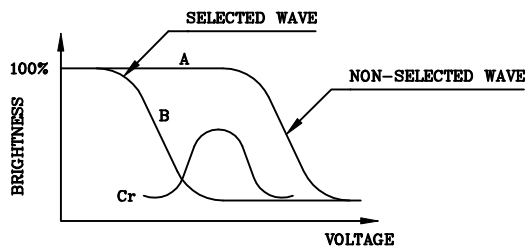

(positive type)

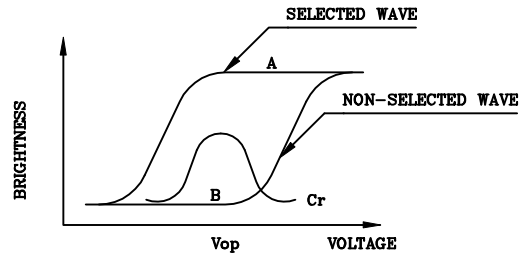

(negative type)

$$\text{Contrast Ratio : } Cr = A/B$$

*Conditions

Viewing Angle : 0
 Frame Frequency : 70Hz
 Applied Waveform : 1/N duty, 1/a bias

REV/DATE	RO/ 04.10.97'					APP	CHK	BY
----------	------------------	--	--	--	--	-----	-----	----

5. BLOCK DIAGRAM

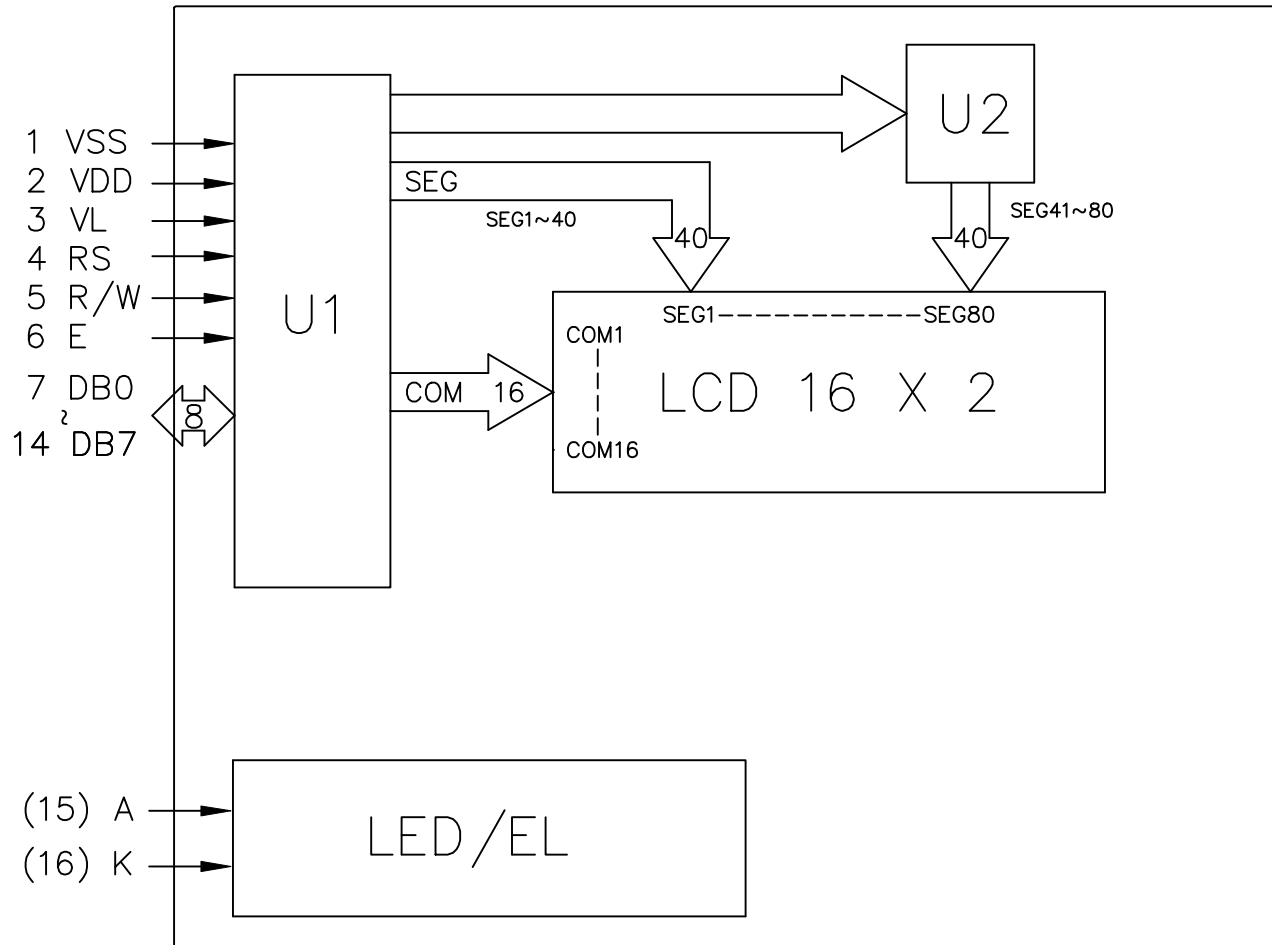

6. INTERNAL PIN CONNECTION

PinNo.	Symbol	Level	Function
1	VSS	—	0V
2	VDD	—	+5V
3	VL	—	—
4	RS	H/L	L: INSTRUCTION CODE INPUT H: DATA INPUT
5	R/W	H/L	H: DATA READ (FROM LCM TO MPU) L: DATA WRITE (FROM MPU TO LCM)
6	E	H, H->L	ENABLE SIGNAL
7	DB0	H/L	DATA BUS LINE
8	DB1	H/L	
9	DB2	H/L	
10	DB3	H/L	
11	DB4	H/L	
12	DB5	H/L	
13	DB6	H/L	
14	DB7	H/L	
(15)	A	—	POWER SUPPLY FOR LED/EL
(16)	K	—	

7. POWER SUPPLY

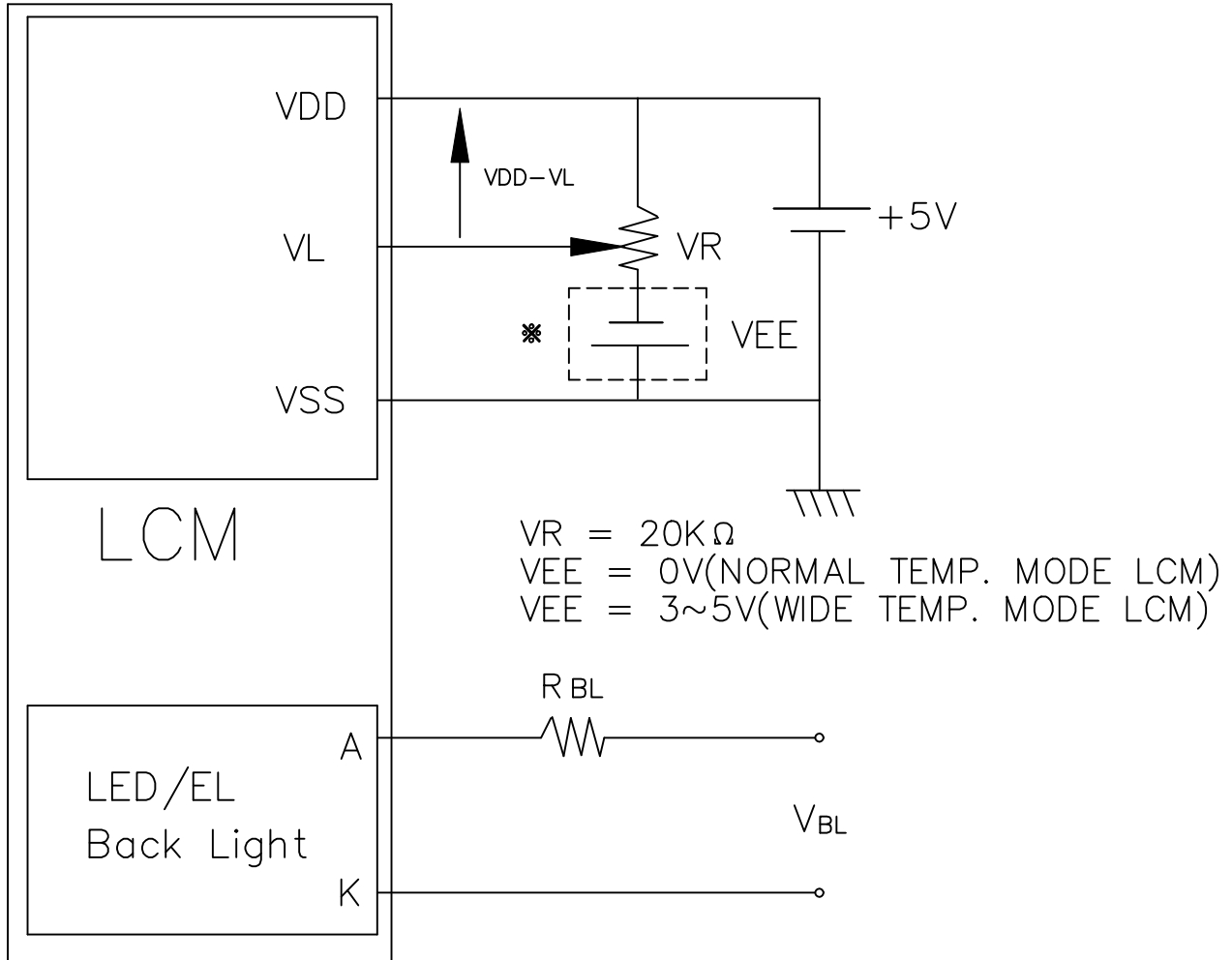

Recommended Value for R_{BL} and V_{BL}

ITEM Back Light		R _{BL}		V _{BL}	
		LED	EL	LED	EL
14 PIN	Using A,K Pads	5 Ω	0 Ω	5V _{DC}	110 V _{AC} 400Hz
	Unusing A,K Pads	0 Ω			
16 PIN		0 Ω			

8. TIMING CHARACTERISTICS

Item	Symbol	Test Condition	Min.	Typ.	Max.	Unit
Enable cycle time	t_{eye}	Fig.a, Fig.b	500	-	-	ns
Enable pulse width	PW_{EH}	Fig.a, Fig.b	230	-	-	ns
Enable rise/fall time	t_{Er}, t_{Ef}	Fig.a, Fig.b	-	-	20	ns
RS, R/W set up time	t_{AS}	Fig.a, Fig.b	40	-	-	ns
RS, R/W hold time	t_{H1}	Fig.a, Fig.b	10	-	-	ns
Data set up time	t_{DSW}	Fig.a	60	-	-	ns
Data output delay time	t_{DDR}	Fig.b	-	-	120	ns
Data write hold time	t_{H2}	Fig.a	10	-	-	ns
Data read hold time	t_{H2}	Fig.b	5	-	-	ns

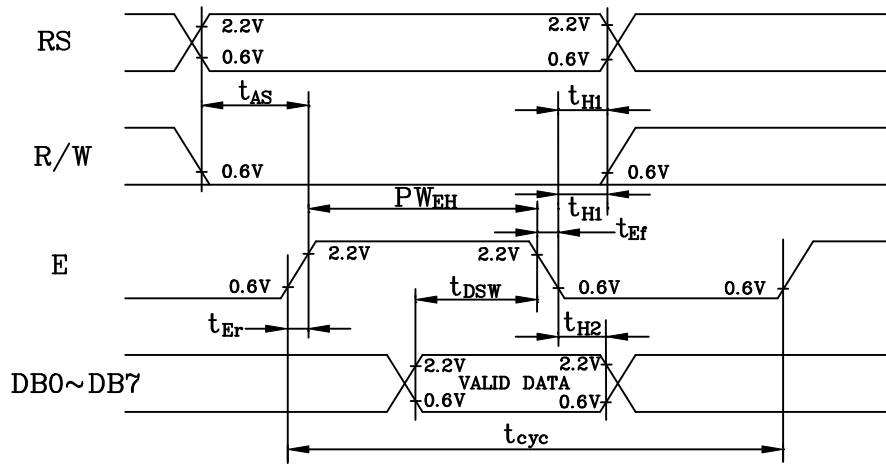

Fig.a Interface timing (data write)

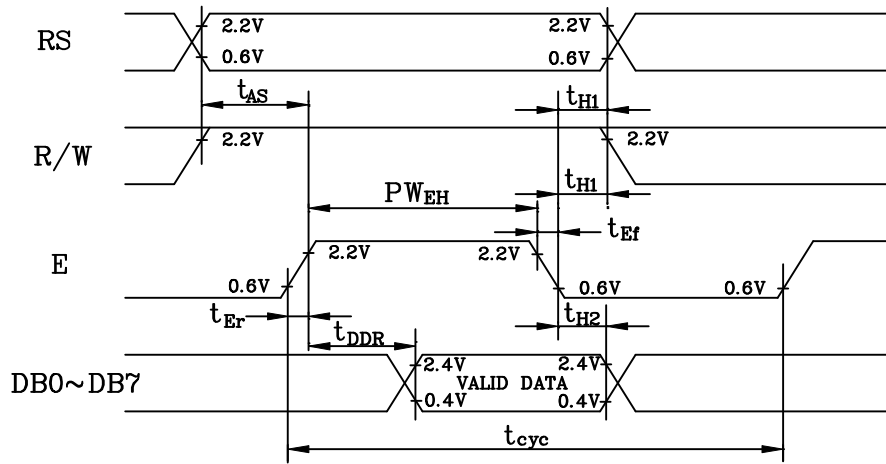

Fig.b Interface timing (data read)

9. RELIABILITY TEST

NO	ITEM	CONDITION			STANDARD	NOTE
1	High Temp. Storage	70°C	120HR		Appearance without defect	
2	Low Temp. Storage	-20°C	120HR		Appearance without defect	
3	High Temp. & High Humidity Storage	40°C 90%RH	120HR		Appearance without defect	
4	Thermal Shock	-20°C,30min → 25°C,5min → 60°C,30min → 25°C,5min (= 1 cycle)			Appearance without defect	5 cycles

10.LCD PRODUCT QUALITY STANDARD

(1) DISPLAY APPEARANCE

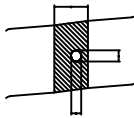
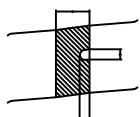
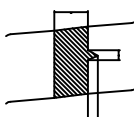
NO	ITEM	C R I T E R I A													
1.	INCLUSIONS (BLACK SPOT , WHITE SPOT , DUST)	(1) ROUND TYPE													
		<table border="1"> <thead> <tr> <th>DIAMETER mm (a*)</th> <th>NO. OF DEFECT*</th> </tr> </thead> <tbody> <tr> <td>a ≦ 0.20</td> <td>NEGLECT</td> </tr> <tr> <td>0.20 < a ≦ 0.35</td> <td>5 MAX</td> </tr> <tr> <td>0.35 < a</td> <td>NONE</td> </tr> </tbody> </table>	DIAMETER mm (a*)	NO. OF DEFECT*	a ≦ 0.20	NEGLECT	0.20 < a ≦ 0.35	5 MAX	0.35 < a	NONE					
DIAMETER mm (a*)	NO. OF DEFECT*														
a ≦ 0.20	NEGLECT														
0.20 < a ≦ 0.35	5 MAX														
0.35 < a	NONE														
		(2) LINEAR TYPE													
		<table border="1"> <thead> <tr> <th>LENGTH mm(L)</th> <th>WIDTH mm(W)</th> <th>NO. OF DEFECT</th> </tr> </thead> <tbody> <tr> <td>N A</td> <td>W ≦ 0.03</td> <td>NEGLECT</td> </tr> <tr> <td>L ≦ 3</td> <td>0.03 < W ≦ 0.08</td> <td>6</td> </tr> <tr> <td>3 < L</td> <td>0.08 < W</td> <td>NONE</td> </tr> </tbody> </table>	LENGTH mm(L)	WIDTH mm(W)	NO. OF DEFECT	N A	W ≦ 0.03	NEGLECT	L ≦ 3	0.03 < W ≦ 0.08	6	3 < L	0.08 < W	NONE	
LENGTH mm(L)	WIDTH mm(W)	NO. OF DEFECT													
N A	W ≦ 0.03	NEGLECT													
L ≦ 3	0.03 < W ≦ 0.08	6													
3 < L	0.08 < W	NONE													
2.	SCRATCH	1.SCRATCH ON PROTECTIVE FILM IS PERMITTED . 2.SCRATCH ON POLARIZER SHALL BE AS FOLLOW:													
		(1) ROUND TYPE													
		<table border="1"> <thead> <tr> <th>DIAMETER mm (a*)</th> <th>NO. OF DEFECT*</th> </tr> </thead> <tbody> <tr> <td>a ≦ 0.15</td> <td>NEGLECT</td> </tr> <tr> <td>0.15 < a ≦ 0.20</td> <td>2 MAX</td> </tr> <tr> <td>0.20 < a</td> <td>NONE</td> </tr> </tbody> </table>	DIAMETER mm (a*)	NO. OF DEFECT*	a ≦ 0.15	NEGLECT	0.15 < a ≦ 0.20	2 MAX	0.20 < a	NONE					
DIAMETER mm (a*)	NO. OF DEFECT*														
a ≦ 0.15	NEGLECT														
0.15 < a ≦ 0.20	2 MAX														
0.20 < a	NONE														
		(2) LINEAR TYPE BE JUDGED BY 1.-(2) LINEAR TYPE													
3.	DENT	DIAMETER < 1.5mm													
4.	BUBBLE	NOT EXCEEDING 0.5mm AVERAGE DIAMETER IS ACCEPTABLE BETWEEN GLASS AND POLARIZING FILM.													
5.	PIN HOLE	(a+b)/2 ≦ 0.15 mm MAXIMUM NUMBER: IGNORED													
		0.15 < (a+b)/2 ≦ 0.20 MAXIMUM NUMBER: 10													
6.	DOT DEFECT	(a+b)/2 ≦ 0.20 mm MAXIMUM NUMBER: IGNORED													
		0.20 < (a+b)/2 ≦ 0.30 MAXIMUM NUMBER: 5 x = WIDTH													
															
															
7.	CONTRAST IRREGULARITY (SPOT)	DIAMETER SPEC.													
		NO. OF DEFECT*													
		a ≦ 0.50 mm	NEGLECT												
		0.50 < a ≦ 0.75	5												
0.75 < a ≦ 1.00	3														
1.00 < a	NONE														
8.	DOT WIDTH	DESIGN WIDTH±15%													
9.	COLOR TONE AND UNIFORMITY	OBVIOUS UNEVEN COLOR IS NOT PERMITTED													

NAN YA PLASTICS CORP. ELEC. MATERIALS DIV. LCD DEPARTMENT	SPECIFICATION	SPEC. NO. : LM119-0 DATE : Apr. 10, 1997 SHEET NO. : 15/16
---	---------------	--

(2) NOTE:

- SAFETY
 - 1.If the LCD panel breaks, be careful not to allow the liquid crystal to touch your skin.
 - 2.If the liquid crystal touches your skin or clothes, please wash it off immediately by using soap and water.

- HANDLING
 - 1.Prevent all contact with static electricity, which can damage the CMOS ICs. The module is packaged in a static-shielding bag to prevent damage during shipment, warehousing and removal from the shipping carton.
 - 2.Do not remove the panel or frame from the module.
 - 3.The polarizing plate on the front surface of the display is very fragile and easily scratched. The module is shipped with a protective liner which must be removed from the polarizing plate prior to assembly.
 - 4.Do not wipe the polarizing plate with a dry cloth, as it may easily scratch the surface of polarizing plate.
 - 5.Do not use ketonics solvent or aromatic solvent on the polarizing plate. Use a soft cloth soaked with plastic-lens cleaning solution.

- STORAGE
 - 1.Store the panel or module in a dark place where the temperature is $25^{\circ}\text{C}\pm 5^{\circ}\text{C}$ and the humidity is below 65% RH.
 - 2.Do not place the module near organics solvents or corrosive gases.
 - 3.Do not crush, shake, or jolt the module.

- TERMS OF WARRANTY
 - 1.Acceptance inspection period
The inspection period is within one month after the arrival of the contracted goods at the buyer's factory site.
 - 2.Applicable warranty period
The warranty period is within twelve months from the date of invoice under normal usage and storage conditions.

- TYPICAL OPERATING LIFETIME OF BACKLIGHT
 - LED : 50,000HR
 - EL : 5,000HR
 - CCFT : 10,000HR

REV/DATE	RO/ 04.10.97'					APP	CHK	BY
----------	------------------	--	--	--	--	-----	-----	----

